

Model 72400

Features, Benefits & Specifications

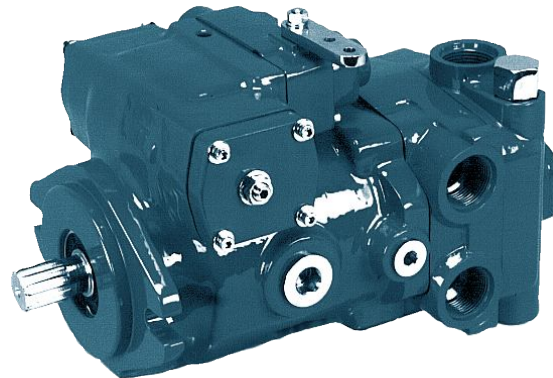

Features

- Modular design
- Durable cast iron housing
- Multiple drain options
- SAE "B" or "B-B" Mount (2 Bolt) Flange
- Numerous shaft options
- Auxiliary or tandem mount capability
- Charge pump
- Control options

Benefits

- Compact package size
- Quiet operation
- Low operator effort
- Improved serviceability

Model 72400

Specifications - Piston Pump

Maximum Displacement	40,6 cm ³ /r [2.48 in ³ /r]	49,2 cm ³ /r [3.00 in ³ /r]
Input Mounting Flange	SAE "B" or "BB"	SAE "B" or "BB"
Flow @ Rated Speed & PSI	140 l/min [37.0 gal/min]	170 l/min [44.8 gal/min]
Maximum Rated Speed	3600 RPM	3600 RPM
Continuous Rated Pressure	210 bar [3000 PSI]	210 bar [3000 PSI]
Maximum Intermittent Pressure	379 bar [5500 PSI]	345 bar [5000 PSI]
Continuous Allowable		
Case Pressure	2 bar [25 PSI]	2 bar [25 PSI]
Maximum Case Drain		
Temperature	107° C [225° F]	107° C [225° F]
Weight per single pump (aprox.)	27 to 28 kg [59 to 62 lbs]	27 to 28 kg [59 to 62 lbs]

Specifications - Internal Gerotor Charge Pump

Displacement Options	
.....	6,9 cm ³ /r [.42 in ³ /r]
.....	13,8 cm ³ /r [.84 in ³ /r]
Operating Pressure Range (std.)	17 to 21 bar [250 to 300 PSI]
Maximum Charge Inlet Vacuum	0,80 bar Abs. [6 inHg]

Model 72400 Performance Data

The charts below are representative of a single 40,6 cm³/r [2.48 in³/r] Variable Displacement Piston Pump. The tests were run at an oil temperature of 82°C [180°F] with viscosity at 9 - 12 cSt [54 - 66 SUS] and the pump at maximum displacement.

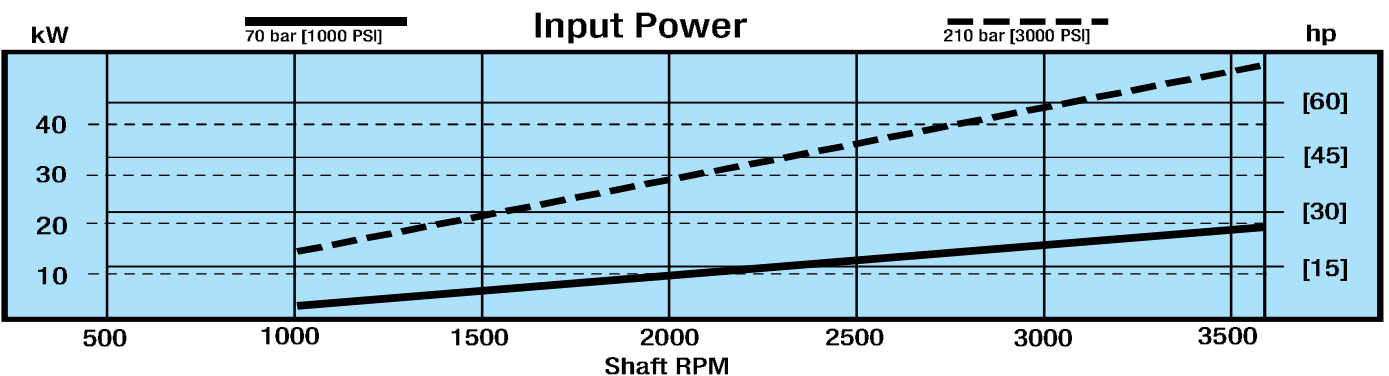
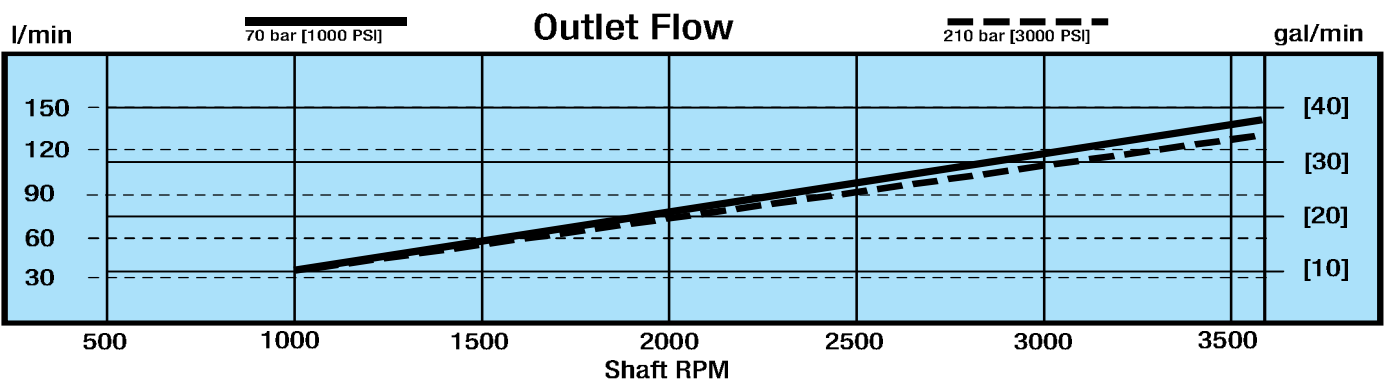
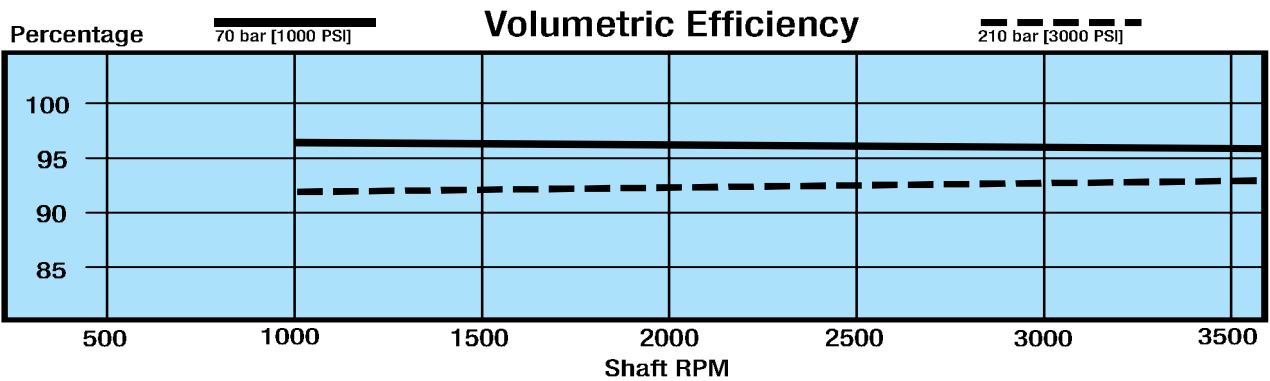
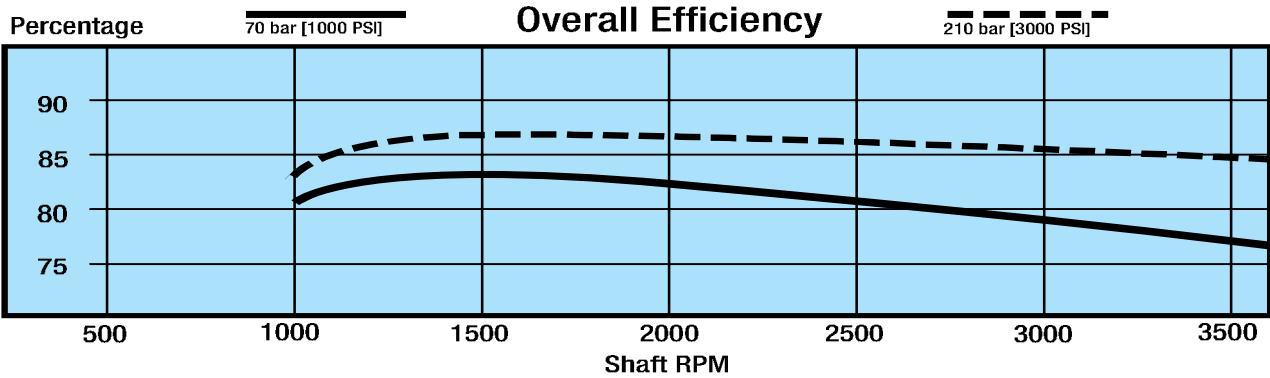

Model 72400

Model Code for the 72400 Piston Pumps

Ordering Instructions

The Model 72400 Servo Controlled piston pumps are selected by using the following Model Code System tailoring the pump configuration to the requirement. Once a pump is built from the model code, a product number will be assigned to that configuration and the pump identified.

Make sure all positions are selected within the 27-digit code for each pump ordered.

Code Example:	A	A	D	R	A	A	A	1	3	E	E	1	T	T	A	M	O	A	0	0	0	A	0	0	0	0	
Position:	1	2	3	4	5	6	7	8	9	10	11	12	13	14	15	16	17	18	19	20	21	22	23	24	25	26	27
																					0	0	A			0	D

Positions 1, 2, 3 - Code Title

- AAD = 40,6 cm³/r [2.48 in³/r] Servo Controlled Variable Displacement Pump
- AAE = 40,6 cm³/r [2.48 in³/r] Servo Controlled Variable Displacement Pump (Tandem Front Pump)
- AAF = 40,6 cm³/r [2.48 in³/r] Servo Controlled Variable Displacement Pump (Tandem Rear Pump)
- ACG = 49,2 cm³/r [3.00 in³/r] Servo Controlled Variable Displacement Pump
- ACH = 49,2 cm³/r [3.00 in³/r] Servo Controlled Variable Displacement Pump (Tandem Front Pump)
- ACJ = 49,2 cm³/r [3.00 in³/r] Servo Controlled Variable Displacement Pump (Tandem Rear Pump)

Position 4 - Input Shaft Rotation

- R = Righthand Rotation (CW)
- L = Lefthand Rotation (CCW)

Position 5 - Input Shaft

- A = 15 Tooth, 16/32 External Spline, 46 [1.81] Shaft Extension A
- B = 41 Tooth, 48/96 External Spline, 24,4 [.96] Shaft Extension B
- C = 13 Tooth, 16/32 External Spline, 41,1 [1.62] Shaft Extension C
- D = Taper 1.502:12, 6,4 [.25] x 19,8 [.78] keyway, 3/8 - 24 UNF Int. Thread, 35,1[1.38] Shaft Extension D
- G = 25.4 [1.00] Dia. Str., 6,4 [.25] x 28,4 [1.12] keyway, 46 [1.81] Shaft Extension (Key Included) G

Position 6 - Output Shaft

- A = 9 Tooth, 16/32 Internal Spline, Accepts 31,8 [1.25] Shaft Extension (for SAE "A" mount only) A
- B = 41 Tooth, 48/96 External Spline, Accepts 24,4 [.96] Shaft Extension (for SAE "B" mount only) B
- F = 11 Tooth, 16/32 Internal Spline, Accepts 31,8 [1.25] Shaft Extension (for SAE "A" mount only) F
- J = 11 Tooth, 16/32 External Spline, Accepts 31,8 [1.25] Shaft Extension (for SAE "B" mount only) J
- (To be used with 36,8 [1.45] spacer) J

Position 7 - Auxiliary Rear Mounting

- A = "A" SAE Flange Series 82-2 A
- B = 2 Bolt "B" SAE Flange Series 101-2 B
- C = "A" SAE Flange Series 82-2 w/ Cover Plate C
- D = "A" SAE Flange Series 82-2 w/ Cover Plate and Mounting Support Holes D
- E = "A" SAE Flange Series 82-2 w/ Mounting Support Holes E
- F = 2 Bolt "B" SAE Flange Series 101-2 w/ Mounting Support Holes F

Position 8 - Charge Pump

- 0 = No charge pump 0
- 1 = 6,9 cm³/r [.42 in³/r] disp. w/1-5/16 - 12 UN-2B SAE O-ring straight thread inlet port (S) 1
- 2 = 13,8 cm³/r [.84 in³/r] disp. w/1-5/16 - 12 UN-2B SAE O-ring straight thread inlet port (S) 2

Position 9 - Charge Pump Relief Setting and Routing

- 0 = No charge pump 0
- 3 = 17- 21 bar [250-300 PSI] (Relieved to Case) 3
- 4 = 17- 21 bar [250-300 PSI], 1- 5/16 - 12 UN-2B SAE O-ring straight thread Outlet port (C3), 3/4 - 16 UNF-2B SAE O-ring straight thread Return Port (C4), (Remote filter and/or heat exchanger, relieved to case) 4

Position 10 - Auxiliary Port, Size and Location (left C1 and right C2)

- D = On both sides w/left side plugged (housing), 3/4 - 16 UNF-2B SAE O-ring straight thread port D
- E = On both sides and both plugged (housing), 3/4 - 16 UNF-2B SAE O-ring straight thread port E

Position 11 - Drain Port Size and Location (left D1 and right D2)

- D = On both sides w/ right side plugged & rear flange drained into housing, 1-1/16 - 12 UN-2B SAE O-ring straight thread port D
- E = On both Sides w/ left side plugged & rear flange drained into housing, 1-1/16 - 12 UN-2B SAE O-ring straight thread port E
- M = On both sides w/ left side plugged & thru drain into mount (front), 1-1/16 - 12 UN-2B SAE O-ring straight thread port M
- S = On both sides w/ both sides plugged & thru drain into mount (front), 1-1/16 - 12 UN-2B SAE O-ring straight thread port S

Position 12 - Main Ports, Size and Location (port A and B)

- 1 = 1- 5/16 - 12 UN-2B O-ring straight thread port, Same Side (Right Side) 1
- 2 = 1- 5/16 - 12 UN-2B O-ring straight thread port, Same Side (Left Side) 2

Positions 13, 14 - Relief Valve Setting for Main Ports

(Select a Setting for port "A" in position 13 and port "B" in Position 14)

- 0 = Check Valve Only 0
- B = 140 bar [2000 PSI] B
- E = 175 bar [2500 PSI] E
- H = 210 bar [3000 PSI] H
- L = 240 bar [3500 PSI] L

Code	Single Unit	Tandem Unit	
		Front	Rear
	Std.	Std.	NA
	NA	NA	Std.
	Opt.	NA	NA
	Opt.	Opt.	NA
	Opt.	NA	NA
	Std.	NA	Std.
	NA	Std.	NA
	Opt.	NA	Opt.
	Opt.	NA	NA
	Opt.	NA	Opt.
	Opt.	Std.	Opt.
	Opt.	Std.	Opt.
	Opt.	NA	Std.
	Opt.	Std.	Std.
	Opt.	NA	NA
	Opt.	NA	Opt.
	Opt.	Std.	NA
	Opt.	Opt.	NA
	Opt.	Std.	NA
	Opt.	Std.	Opt.
	Opt.	Std.	Opt.
	Opt.	Opt.	Opt.
	Opt.	Opt.	Opt.
	Opt.	Opt.	Opt.
	Opt.	Opt.	Opt.

Model Code for the 72400 Piston Pumps

	Code	Single Unit	Tandem Unit	
			Front	Rear
N = 275 bar [4000 PSI]	N	Opt.	Opt.	Opt.
Q = 310 bar [4500 PSI]	Q	Opt.	Opt.	Opt.
T = 345 bar [5000 PSI]	T	Std.	Std.	Std.
Y = 379 bar [5500 PSI]	Y	Opt.	Opt.	Opt.
Position 15 - Additional Functions				
0 = No Additional Functions	0	Std.	Std.	Std.
A = Bypass Valve	A	Opt.	Opt.	Opt.
Positions 16, 17 - Control Assembly				
Manual Control				
M0 = No Additional Features	M0	Std.	Std.	Std.
MA = Neutral Lockout Switch (Includes Wide Band Neutral)	MA	Opt.	Opt.	Opt.
MB = Neutral Detent (Includes Wide Band Neutral)	MB	Opt.	Opt.	Opt.
MC = Wide Band Neutral	MC	Opt.	Opt.	Opt.
Port Plate				
P0 = No Additional Features	P0	Opt.	Opt.	Opt.
Hydraulic Remote Control				
HA = 5-15 bar [72-217 PSI] Pilot Pressure range, 2X Port .4375-20 UNF-2B SAE O-ring Port	HA	Opt.	Opt.	Opt.
Electrohydraulic Control				
EC = Electronic Proportional Control 12 Vdc without Electronic Driver	EC	Opt.	Opt.	Opt.
ED = Electronic Proportional Control 24 Vdc without Electronic Driver	ED	Opt.	Opt.	Opt.
EE = Electronic Proportional Control 12/24 Vdc and Electronic Driver with 1 to 6 Vdc Potentiometric Command Input	EE	Opt.	Opt.	Opt.
EG = Electronic Proportional Control 12/24 Vdc and Electronic Driver with 4 to 20 mA Command Input	EG	Opt.	Opt.	Opt.
EL = Electronic Proportional Control 12 Vdc and Electronic Driver with ± 100 mA Command Input	EL	Opt.	Opt.	Opt.
Solenoid Operated				
SA = 3 pos (FNR) 12 Vdc solenoids with Weather Pack Connectors (locations at port s1 and s2)	SA	Opt.	Opt.	Opt.
SB = 2 pos 12 Vdc solenoid with Weather Pack Connectors (location at port s1)	SB	Opt.	Opt.	Opt.
SC = 2 pos 12 Vdc solenoid with Weather Pack Connectors (location at port s2)	SC	Opt.	Opt.	Opt.
Position 18 - Destroke Valve				
0 = Not required	0	Std.	Std.	Std.
1 = with 12 VDC Coil and Weather Pack Connector	1	Opt.	Opt.	Opt.
2 = with 24 VDC Coil and Weather Pack Connector	2	Opt.	Opt.	Opt.
3 = with 12 VDC Coil and DIN 43650 Connector	3	Opt.	Opt.	Opt.
4 = with 24 VDC Coil and DIN 43650 Connector	4	Opt.	Opt.	Opt.
Position 19 - Supply Orifice (location p)				
0 = No Supply Orifice (NA for pumps w/ destroke)	0	Opt.	Opt.	Opt.
A = 0,71 mm [.028 in]	A	Opt.	Opt.	Opt.
B = 0,81 mm [.032 in]	B	Opt.	Opt.	Opt.
C = 0,91 mm [.036 in]	C	Std.	Std.	Std.
D = 1,02 mm [.040 in]	D	Opt.	Opt.	Opt.
E = 1,12 mm [.044 in]	E	Opt.	Opt.	Opt.
F = 1,32 mm [.052 in] (Maximum orifice size if position 18 selection is 1 thru 4)	F	Opt.	Opt.	Opt.
G = 1,45 mm [.057 in] (NA for pumps w/ destroke)	G	Opt.	Opt.	Opt.
H = 1,65 mm [.065 in] (NA for pumps w/ destroke)	H	Opt.	Opt.	Opt.
J = 1,85 mm [.073 in] (NA for pumps w/ destroke)	J	Opt.	Opt.	Opt.
Position 20 - Control Orifice (location s1 & s2)				
0 = No Control Orifice	0	Std.	Std.	Std.
A = 0,71 mm [.028 in]	A	Opt.	Opt.	Opt.
B = 0,81 mm [.032 in]	B	Opt.	Opt.	Opt.
C = 0,91 mm [.036 in]	C	Opt.	Opt.	Opt.
D = 1,02 mm [.040 in]	D	Opt.	Opt.	Opt.
E = 1,12 mm [.044 in]	E	Opt.	Opt.	Opt.
F = 1,32 mm [.052 in]	F	Opt.	Opt.	Opt.
G = 1,45 mm [.057 in]	G	Opt.	Opt.	Opt.
Position 21 - Special Control Option				
Manual Control (only)				
0 = No Special Control Options (Standard Control Lever Position)	0	Std.	Std.	Std.
Positions 22, 23 - Paint				
OA = Primer	OA	Std.	Std.	Std.
OB = Black	OB	Opt.	Opt.	Opt.
Positions 24, 25 - Special Features				
00 = No Special Features	00	Std.	Std.	Std.
BB = Adjustable Displacement Limiter, Both Sides	BB	Opt.	Opt.	Opt.
Position 26 - Identification				
0 = Standard	0	Std.	Std.	Std.
Position 27 - Design Code				
D = Eaton - assigned design code				

72400

Input Shafts

Code Position 5

Dimensions are in millimeters [inches], unless otherwise specified.

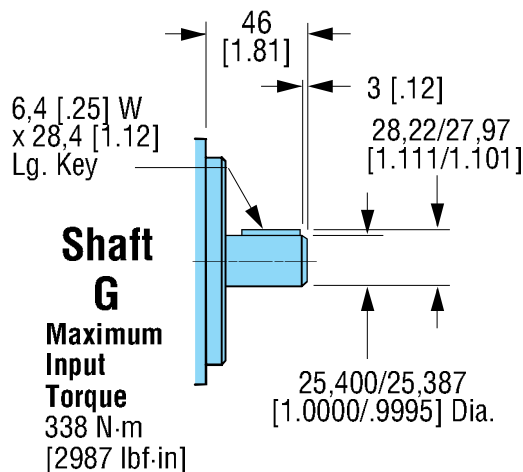
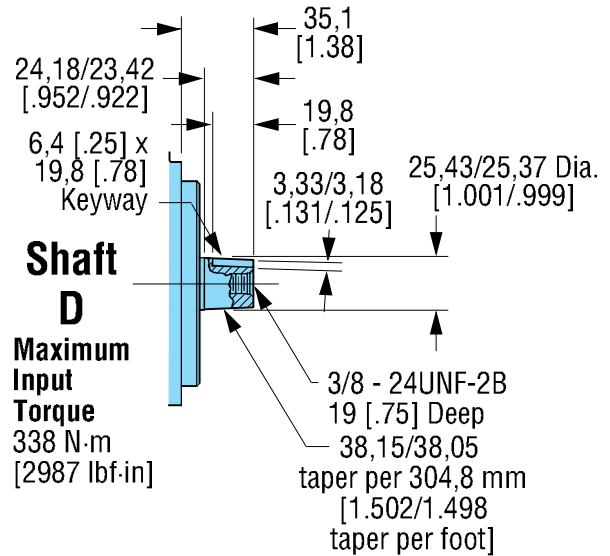
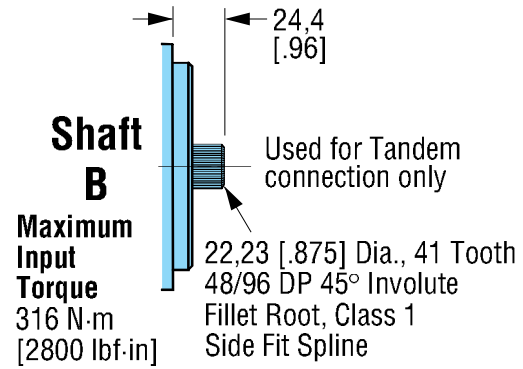
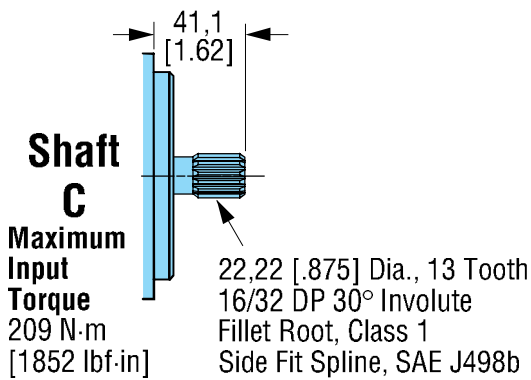
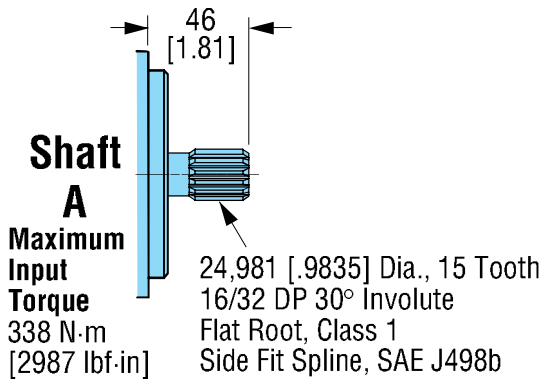

Torque Note:
 The combined torque required to turn multiple pumps must not exceed the torque rating of the input drive shaft of the front piston pump.
 Consult an Eaton representative and/or Eaton engineering on side load recommendations.

Ordering Note:
 Input and output shafts (code position 5 & 6) must be selected in relationship to pump code (position 1, 2, & 3).

72400

Output Shafts - Code Position 6

9 Tooth, 16/32 DP Int., 15,875
 [.6250] O.D., Accepts 31,8 [1.25]
 Shaft Extension, "A" Mount SAE J498b

**Position 6
 Shaft A**

Torque limit on internal rear spline of piston pump with internal charge pump must not exceed 54 N·m [480 lbf·in]. Piston pump without internal charge pump must not exceed 76 N·m [672 lbf·in].

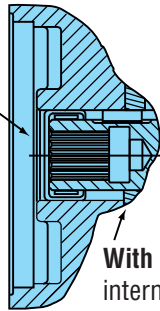

With internal charge.

11 Tooth, 16/32 DP Int., 19,33
 [.761] O.D., Accepts 31,8 [1.25]
 Shaft Extension, "A" Mount SAE J498b

**Position 6
 Shaft F
 Maximum Torque
 119 N·m [1050 lbf·in]**

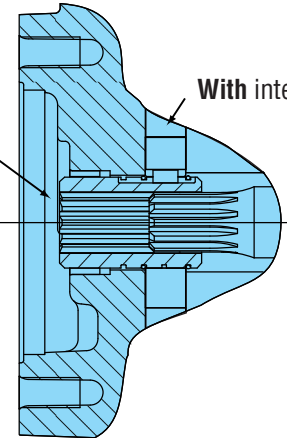

With internal charge.

11 Tooth, 16/32 DP Ext., 19,05
 [.750] O.D., Accepts 31,8 [1.25]
 Shaft Extension, "A" Mount SAE J498b
 (Used with spacer)

**Position 6
 Shaft J
 Maximum Torque
 119 N·m [1050 lbf·in]**

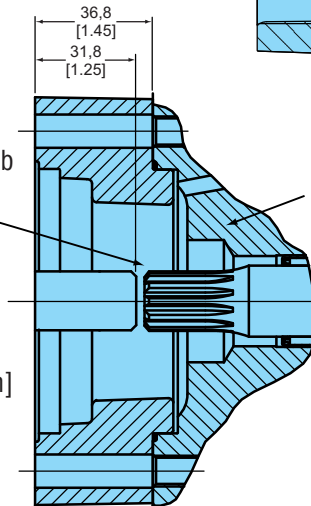

Without internal charge

13 Tooth, 16/32 DP External, 21,81
 [.8585] O.D., Accepts 41,1 [1.62] Shaft
 Extension "B" Auxiliary Mount,
 SAE J744

**Position 6
 Shaft L
 Maximum Torque
 209 N·m [1852 lbf·in]**

Without internal charge

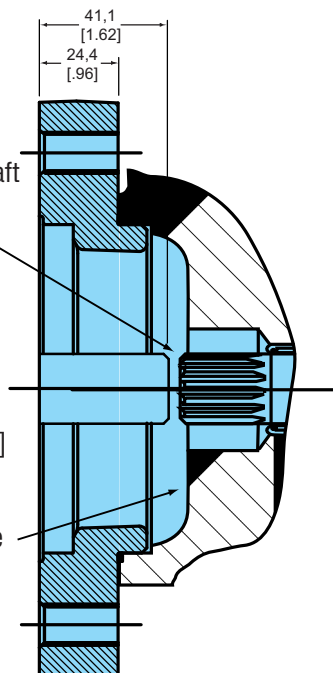

41 Tooth, 48/96 DP Extension, 22,225
 [.8750] O.D., Accepts 24,4 [.96] Shaft
 Extension "B" Auxiliary Mount,
 SAE J498b

**Position 6
 Shaft B
 Maximum Torque
 316 N·m [2,800 lbf·in]**

41 Tooth for tandem connections on rear of front pump.

Tandem Servo Piston Pump
 SAE "B" Mounting Kit #72400-902:
 Includes 41T coupling, o-ring, cap screws (2),
 and washer.

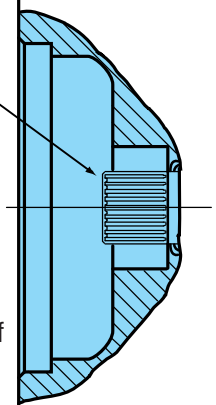

72400

Auxiliary Rear Mounting

Code Position 7

Dimensions are in millimeters [inches], unless otherwise specified.

2 Bolt "A" Auxiliary Mounting Flange
(Rear of Single or Tandem Rear Pump)

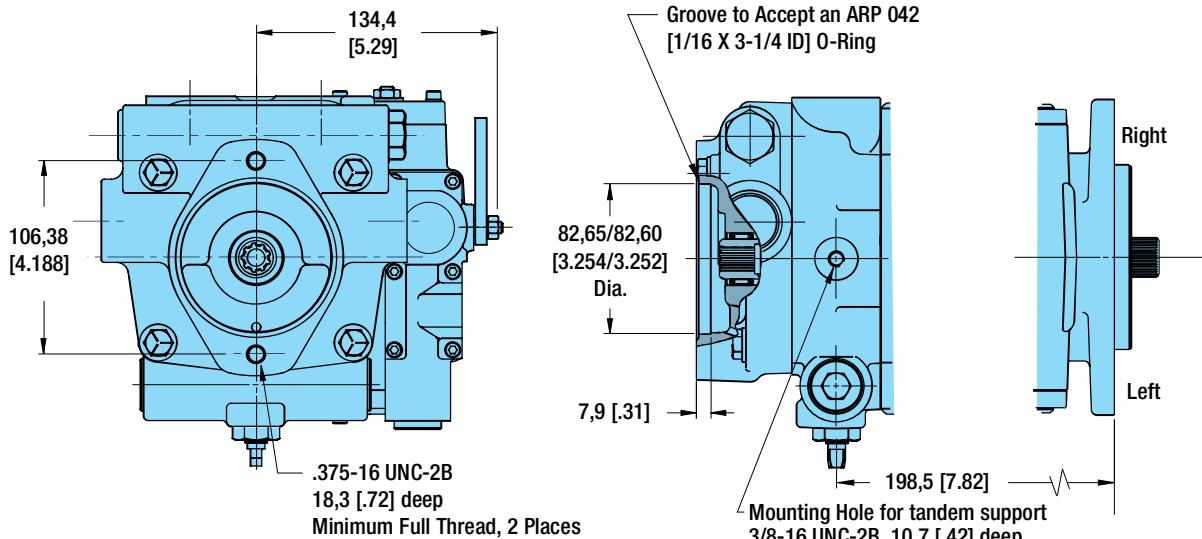

2 Bolt "B" Auxiliary Mounting Flange
(Rear of Front Pump)

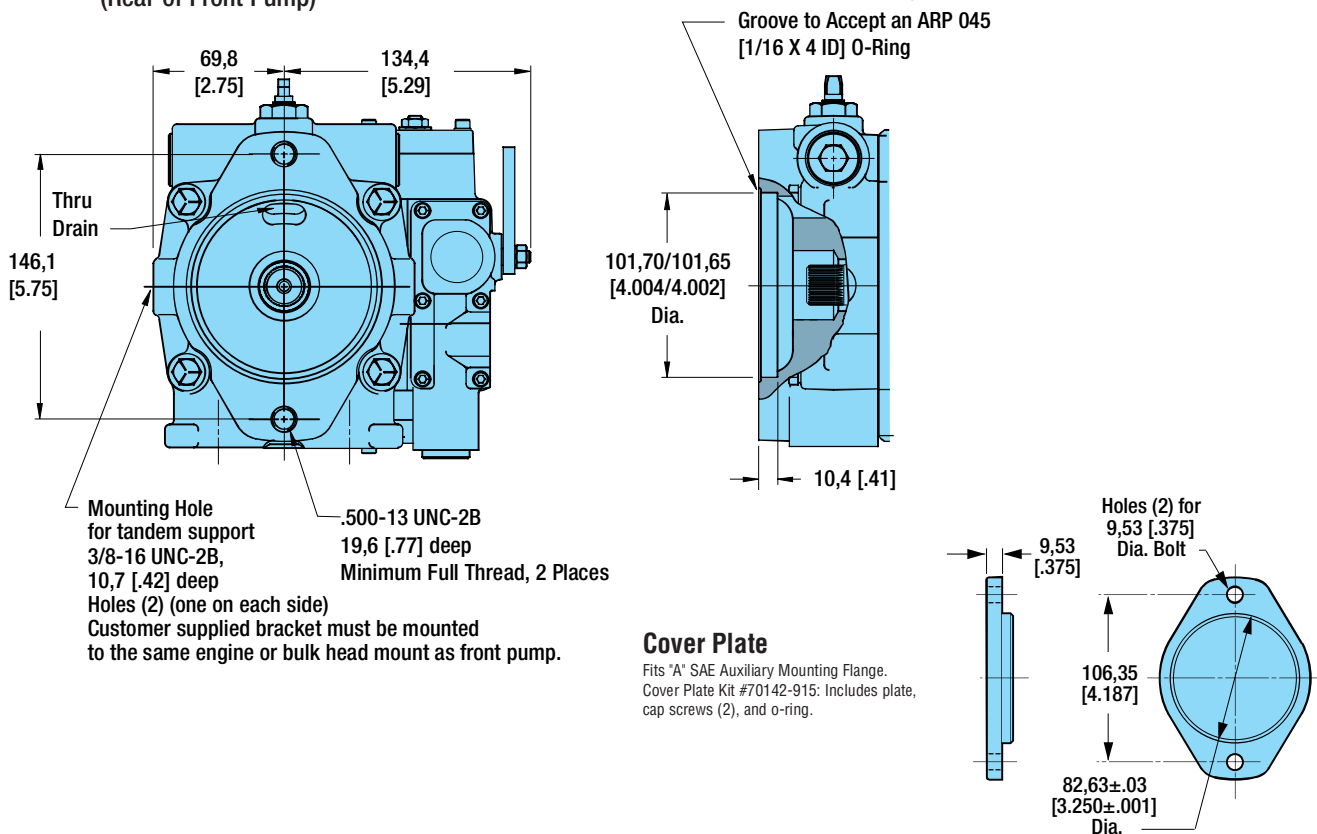

Model 72400

72400

Charge Pump Routing and Location

Code Position 9

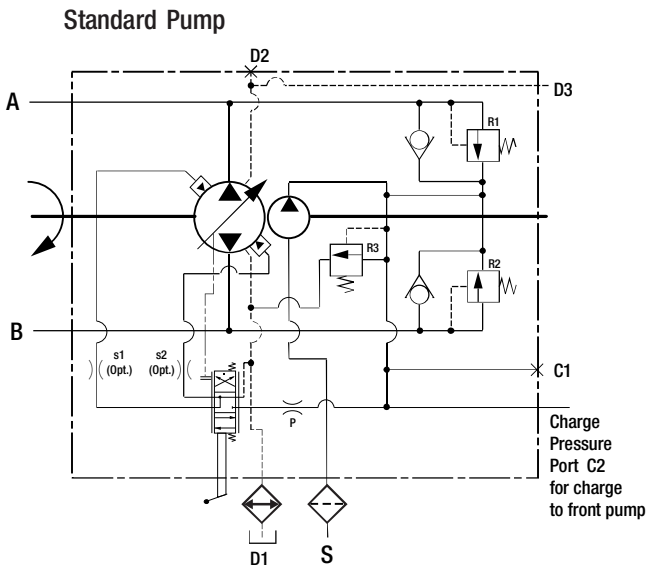

Charge Pump with Remote Filter/ Heat Exchanger Ports

(Filter and heat exchanger supplied by customer.)

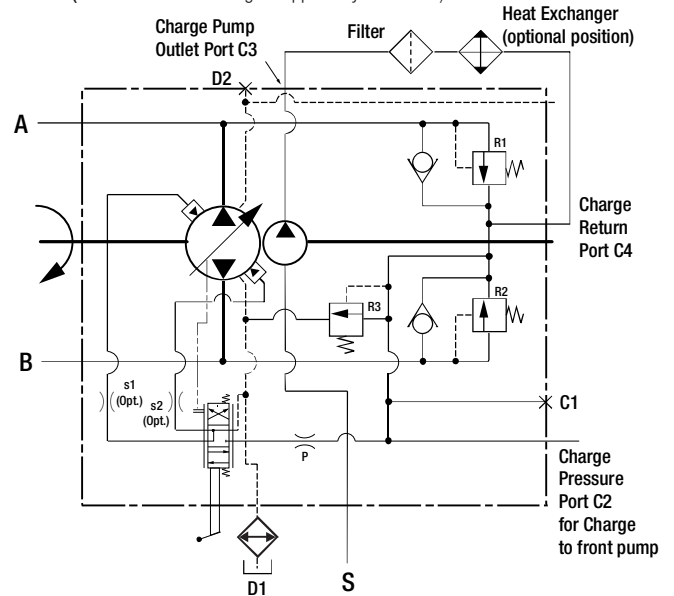

Charge Outlet Port Location

The charge outlet and return port is located in the charge pump housing, opposite of the suction port and charge relief valve.

For further detail on port relationship to rotation and position, refer to installation drawings.

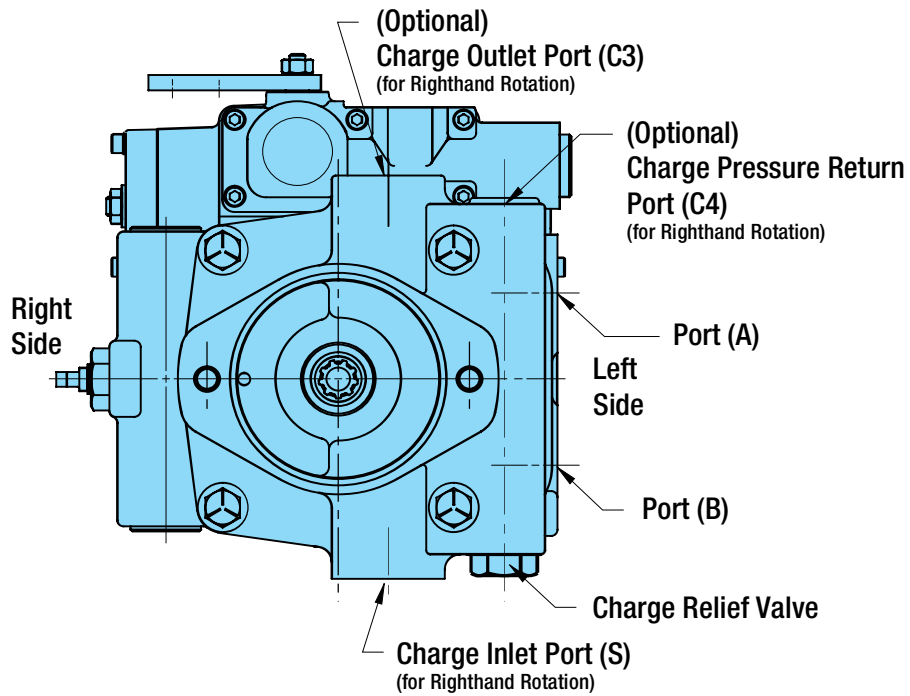

All left (CCW) or right (CW) directions given are viewed looking at the input shaft end of the pump.

Model 72400

72400

Auxiliary and Drain Port Locations

Code Position 10 and 11

(For dimensions, refer to Installation drawings.)

Drain Locations in Rear of Pumps

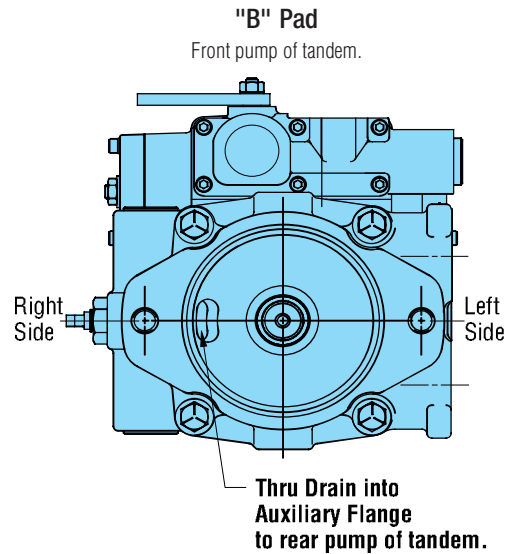
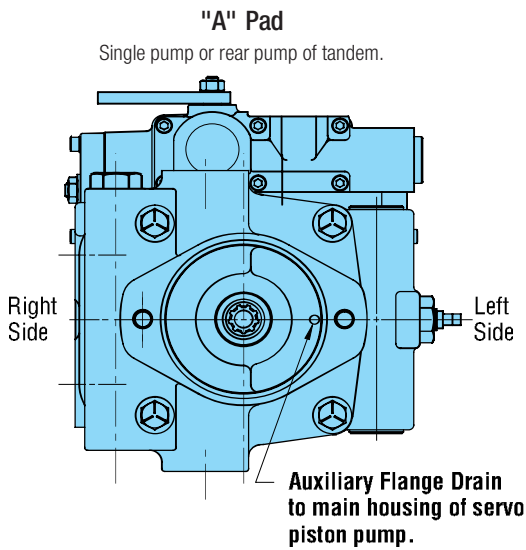

Side and Front of Pump

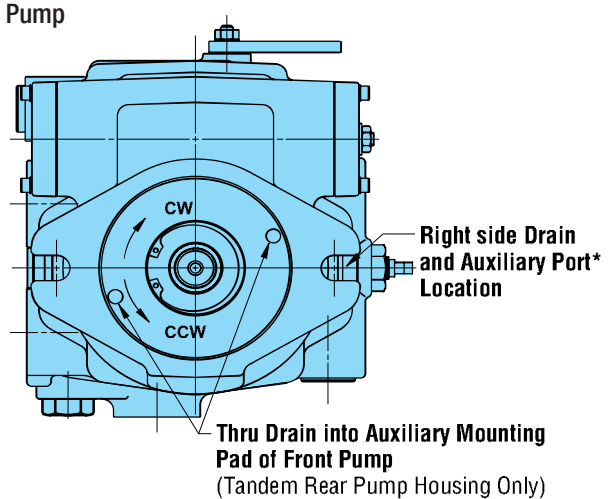
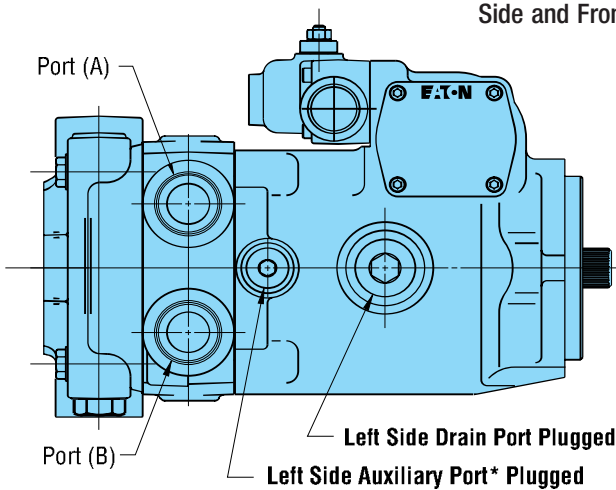

*NOTE: Auxiliary port required in rear and front pump of tandem to provide charge flow and pressure to front pump.

All left (CCW) or right (CW) directions given are viewed looking at the input shaft end of the pump.

72400

Main Ports and Relief Valve Location

Code Position 12, 13, and 14

(For dimensions, refer to installation drawings.)
 Charge pump position must stay in relationship to backplate as pictured below.

*Righthand Rotation (CW)

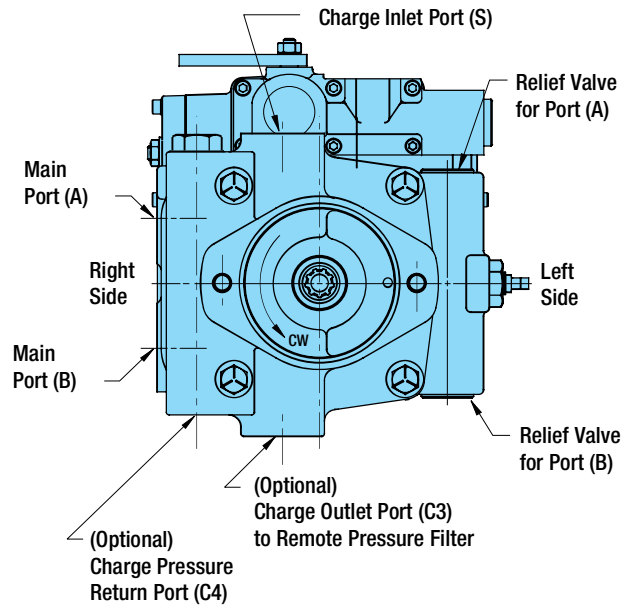
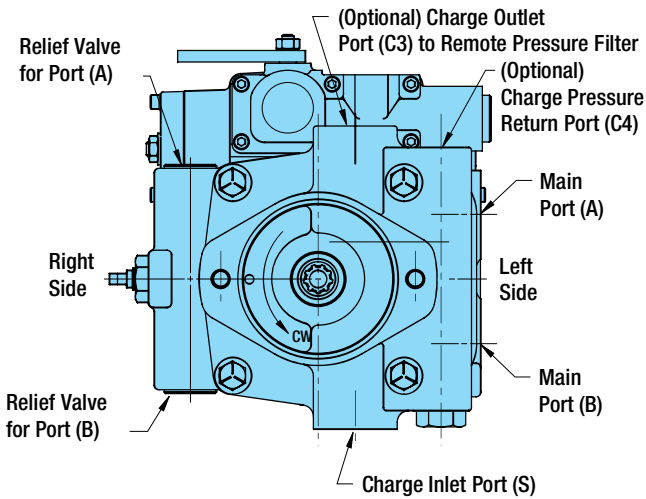

*Lefthand Rotation (CCW)

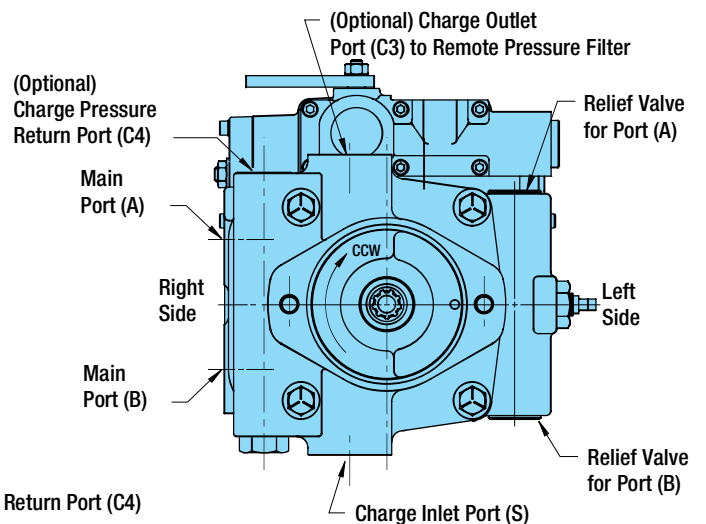
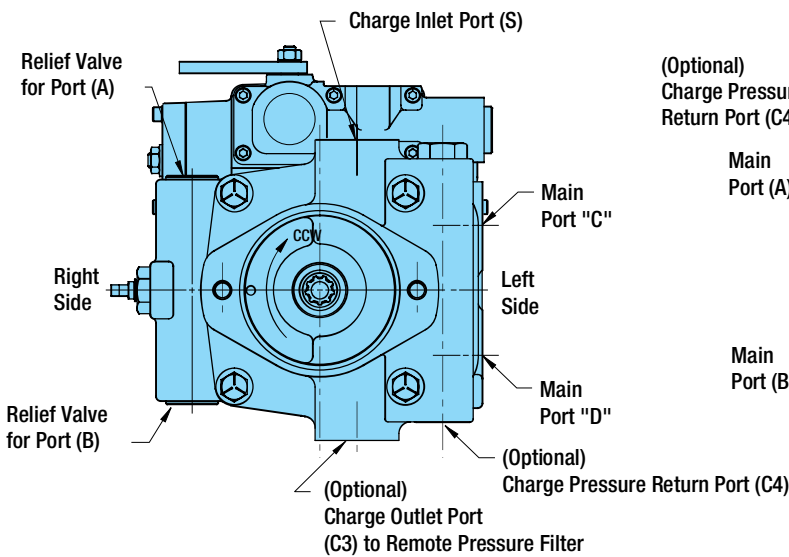

*All left (CCW) or right (CW) directions given are viewed looking at the input shaft end of the pump.

72400

Additional Functions

Code Position 15

(For dimensions, refer to installation drawings.)

Bypass Valve

Opens the closed loop hydraulic circuit, allowing limited movement of a machine.

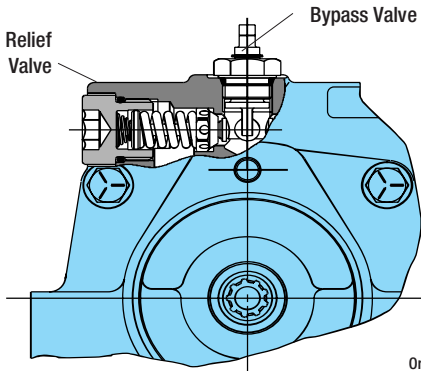

Order #72400-900 kit for Bypass Valve separately.

Dimensions are in millimeters [inches], unless otherwise specified.

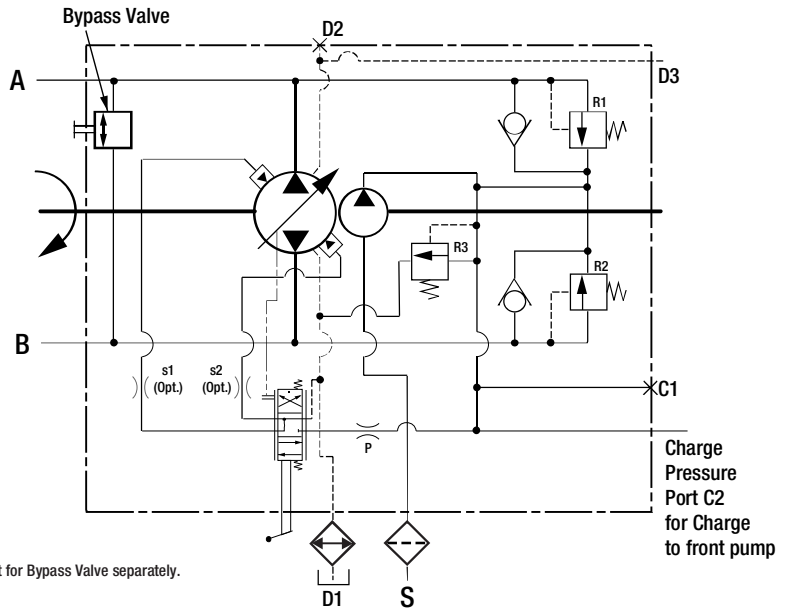

Port Plate Control

Code Position 16,17, and,18

The port plate is commonly used as a slave control that receives commands from other controls in the same system.

Minimum required control-pressure is 17 bar [250 PSI]

Righthand (CW) Input Rotation

Pressure to Control Port 1
Pressure to Control Port 2

Output Flow

Port (B)
Port (A)

Lefthand (CCW) Input Rotation

Pressure to Control Port 1
Pressure to Control Port 2

Output Flow

Port (A)
Port (B)

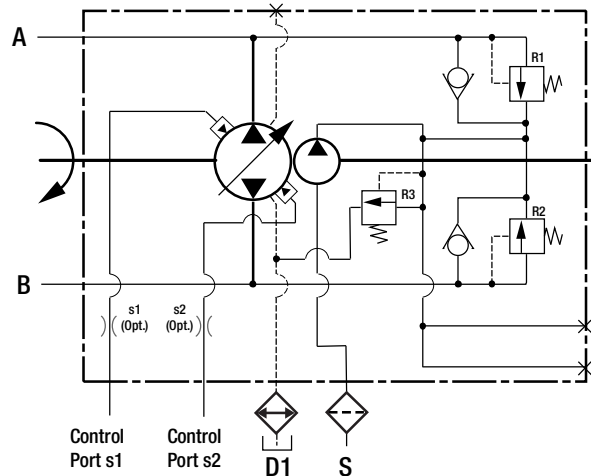

Model 72400

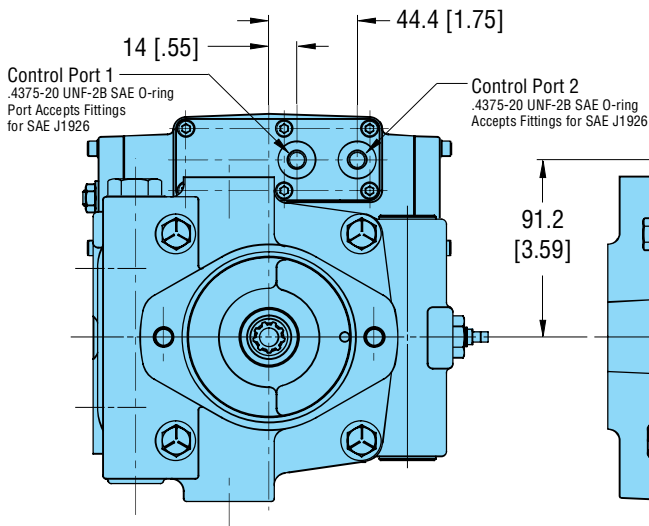

72400

Manual Control

Code Position 16,17, and,18

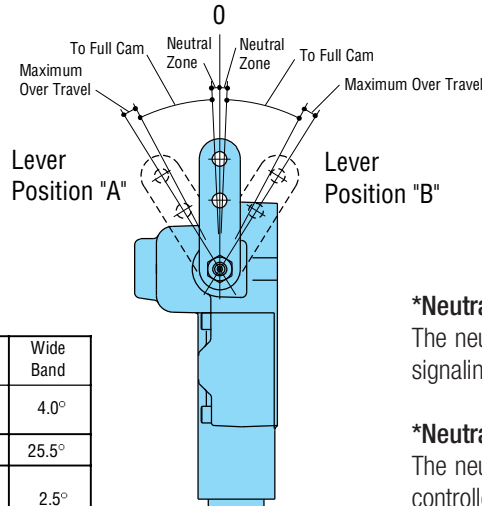

Dimensions are in millimeters [inches], unless otherwise specified.

Control Lever Travel	Standard Band		Wide Band	
	Standard Band	Wide Band	Standard Band	Wide Band
Neutral Zone	2.5°	4.0°		
Max. Displ.	25.5°	25.5°		
Maximum Over Travel	4.0°	2.5°		

*Neutral Detent Feature

The neutral detent provides a positive, centered feeling to the handle, signaling the operator when the pump is in neutral position.

*Neutral Lockout Feature

The neutral lockout switch consists of an electrical switch installed on the controller. This switch closes at the neutral position of the input lever and opens if lever is rotated either direction. The electronic "lockout" prevents the operator from starting any auxiliary functions unless the pump is in neutral position.

*Destroke Valve Feature

The destroke valve provides an emergency return to neutral and must be energized in order for the pump to stroke. If at any time power is interrupted to the solenoid, the pump will destroke to neutral.

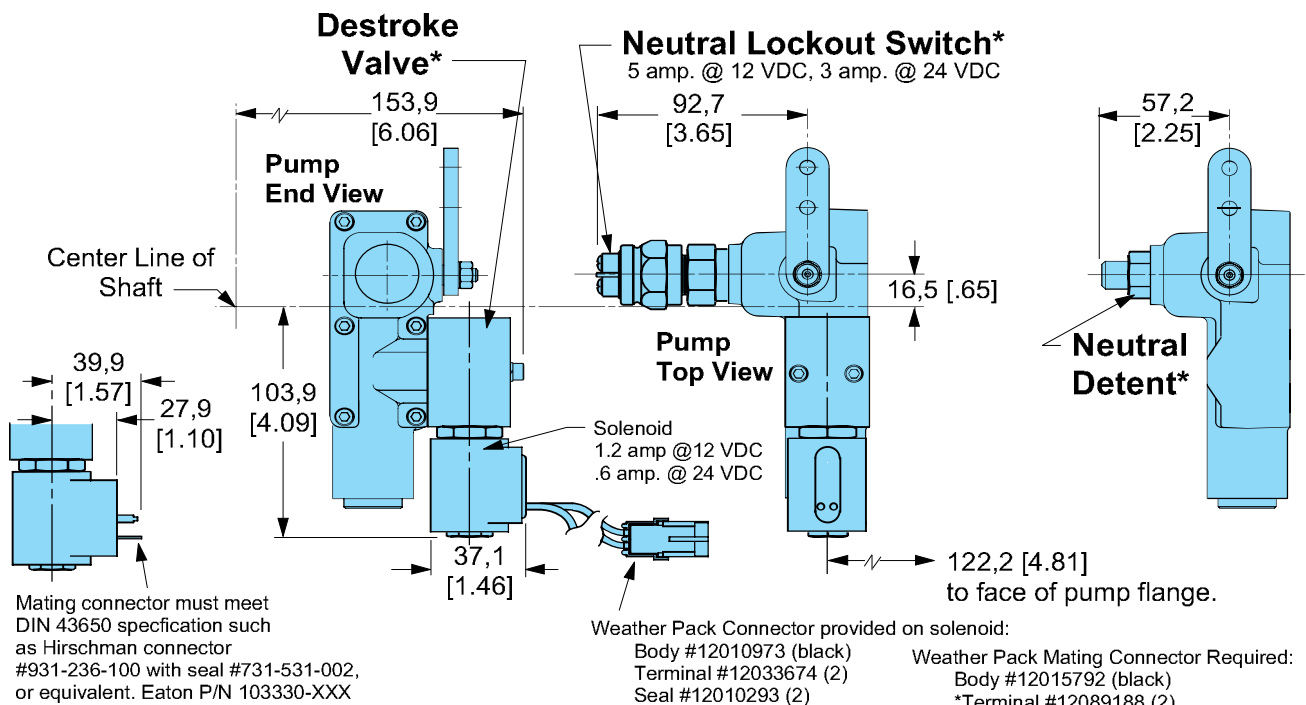

Model 72400

72400

Hydraulic Remote Control

Code Position 16,17

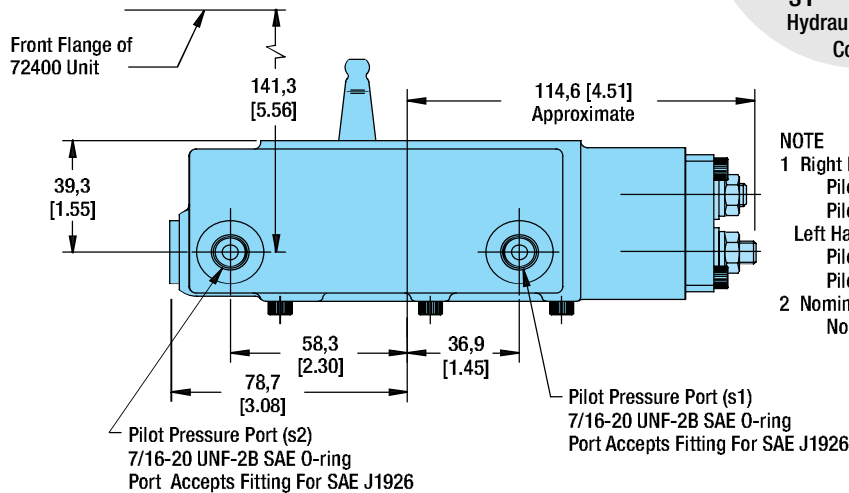
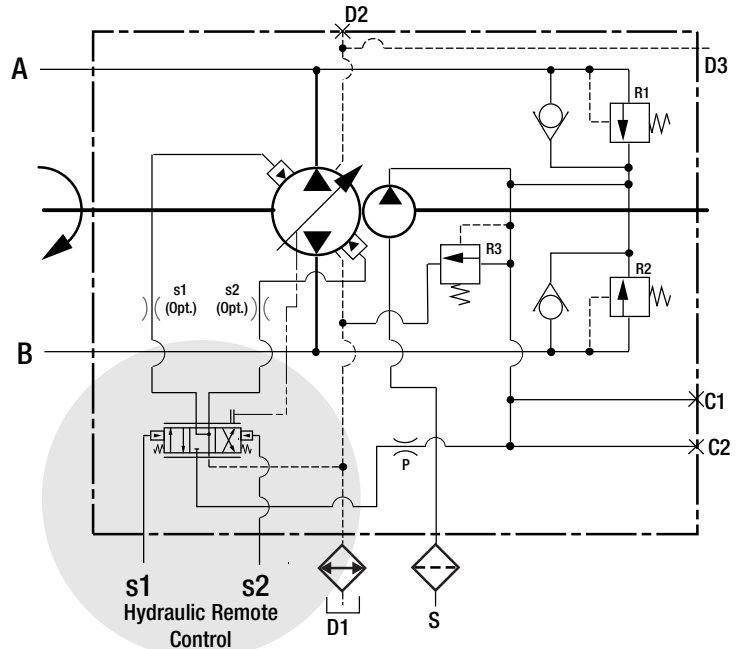
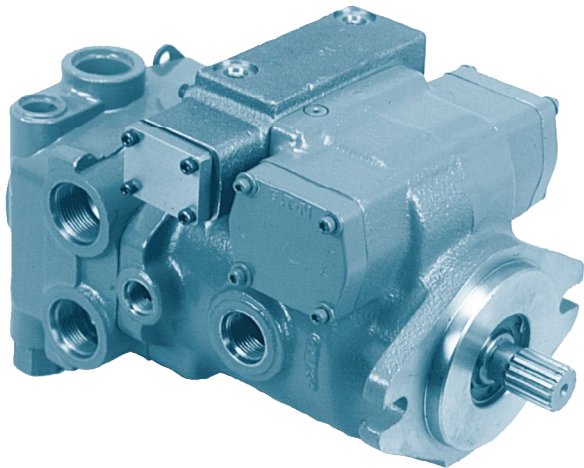

NOTE

- 1 Right Hand (Clockwise) Rotation
Pilot Press Port -1 Pressurized...flow From System Press Port -B
Pilot Press Port -2 Pressurized...flow From System Press Port -A
- Left Hand (Counter Clockwise) Rotation
Pilot Press Port -1 Pressurized...flow From System Press Port -A
Pilot Press Port -2 Pressurized...flow From System Press Port -B
- 2 Nominal Threshold Pressure 5 bar [72.5 PSI]
Nominal Max Displacement Pressure 15 bar [217.6 PSI]

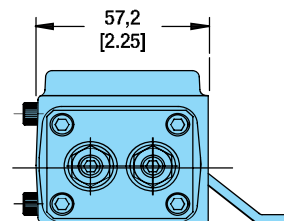
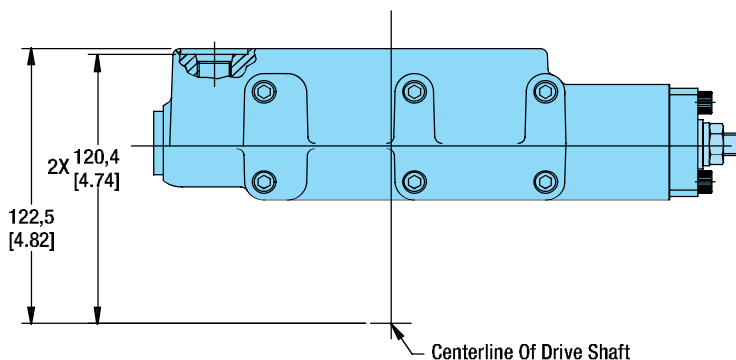

Hydraulic Remote Control Conversion Kit

Order Part Number 72400-919

Includes: Control sub-assembly (1pc), Socket head cap screws (6 pc), Control housing gasket (1pc)

Model 72400

72400 Electronic Proportional Displacement Control

Code Position 16,17

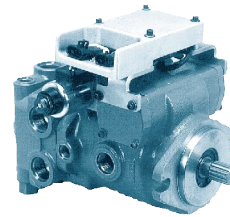

Model Code	Model Code Description	Typical Input Devices	Nominal Command Input Impedance of Electronics Module
	Command Input Signal		
EE	1 to 6 Vdc Potentiometric	Joysticks or Potentiometers with a resistance between 160 ohms and 50K ohms.	500K Ohms
EG	± 20 mA Current loop (4-20 mA)	Programmable Logic Controllers (PLC)	250 Ohms
EL	± 100 mA differential	Torque motor servo valve current drivers	28 Ohms
EC	12 Volts	Requires customer supplied electronics	
ED	24 Volts		

The Electronic Proportional (EP) displacement control is ideal for applications requiring electronic pump displacement control. The EP displacement control provides the flexibility of three command input choices. Control components include a proportional solenoid actuated valve assembly and an electronic solenoid driver module mounted on the pump. The control driver module converts a command input signal to a proportional current output to the proportional solenoids resulting in a proportional pump displacement.

The EP displacement control has been designed to withstand the rigors of off-highway equipment environmental conditions.

EP Displacement Control Features

- Ease of installation
- Automotive style environmentally sealed Metri-Pack connectors
- Operates from 12 or 24 Vdc power supply
- External fuse (customer supplied):
3A for 12 Vdc system, 1A for 24 Vdc system
- Three choices for command input signal
- Operating temperature range -40° C to +85° C
- Control driver module encapsulated for environmental protection
- Closed loop current control compensates for resistance change of the proportional solenoids due to temperature variations
- Return to neutral for loss of power, or loss of command input signal
- Mechanical feedback of swashplate position for closed loop control
- External neutral adjustment
- Manual override capability
- Control drive module qualification per SAE J1455, SAE J1113, CISPR 25

Control Driver Module Qualification
(Contact Eaton for Specific Levels)

- SAE J1455 - Recommended Environmental Practices for Electronic Equipment Design

Humidity/Temperature Extreme Cycling
Salt Spray
Splash & Immersion
Steam Cleaning/High Pressure Wash
Vibration
Mechanical Shock
Temperature Cycling
Load Dump Transients
Inductive Load Switching Transients

- SAE J1113 - Electromagnetic Susceptibility Measurement Procedures for Vehicle Components

EMI/EMC - Conducted & Radiated Immunity

- CISPR 25 - International Electrotechnical Commission "Limits and Methods of Measurement of Radio Disturbance Characteristics for the Protection of Receivers used on Board Vehicles".

EMI /EMC - Conducted & Radiated Emissions

72400

Electronic Proportional Displacement Control

Code Position 16,17 (EE, EG, EL) Cont.

Interface Schematic

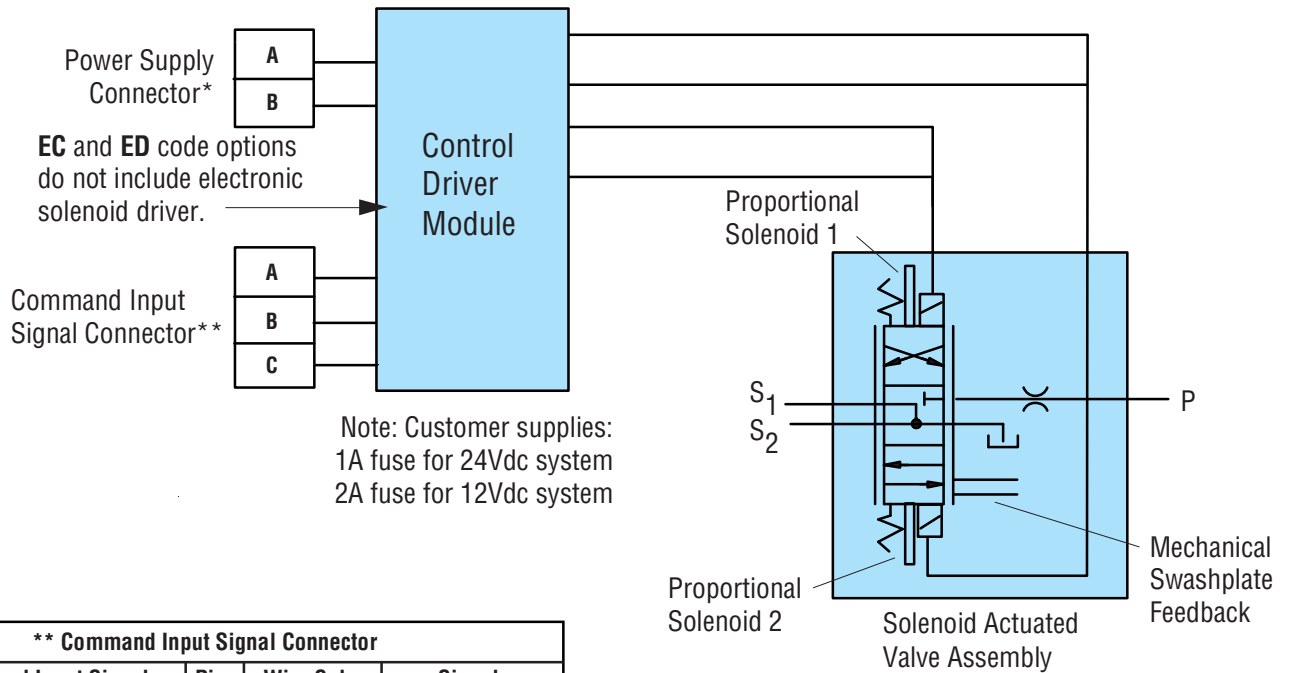

** Command Input Signal Connector			
Command Input Signal	Pins	Wire Color	Signal
1 to 6 Vdc Potentiometric	A	Black	Ref Low - 1 Vdc
	B	Green	Command (wiper)
	C	Red	Ref Hi - 6 Vdc
± 20 mA Current loop (4-20 mA)	A	Orange	Loop Return
	B	White	Loop In
	C	No Connection Required*	
± 100 mA differential	A	Blue	Loop Return
	B	White	Loop In
	C	No Connection Required*	

* Mating connector kit 990762-000 contains plug to be used to seal mating end connector.

Solenoid Actuated Valve Assembly

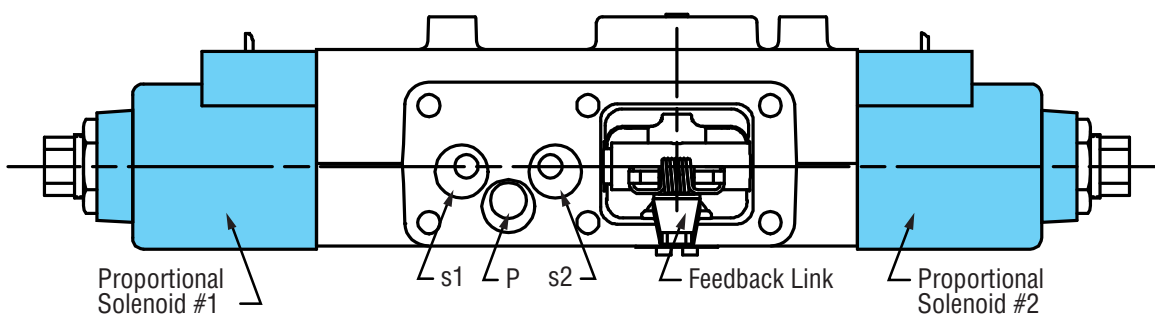

Model 72400

72400

Electronic Proportional Displacement Control

Code Position 16,17

(EE, EG, EL) Cont.

Mating Connector Kit: Eaton P/N 990762-000*
Recommended: Wire Size 16-18 AWG,
 Cable Dia. 2.03 - 2.80 mm

Kit includes:
 Mating Connectors for 2-pin Power Supply Connector,
 3-pin Command Input Signal Connector

***Delphi/Packard**
Mating Connector Part Numbers:
 Recommended: Wire Size 16-18 AWG,
 Cable Dia. 2.03 - 2.80 mm
 Reference Source: Pioneer-Standard Electronics 1-800
 257-6613

1) Power Supply 2-pin connector
 Connector P/N 1205 2641
 Terminal P/N 1204 8074
 TPA P/N 1205 2634
 Cable Seal 1204 8086

2) Command Input Signal 3 Pin Connector
 Connector P/N 1211 0293
 Terminal P/N 1204 8074
 TPA P/N 1205 2845
 Cable Seal 1204 8086

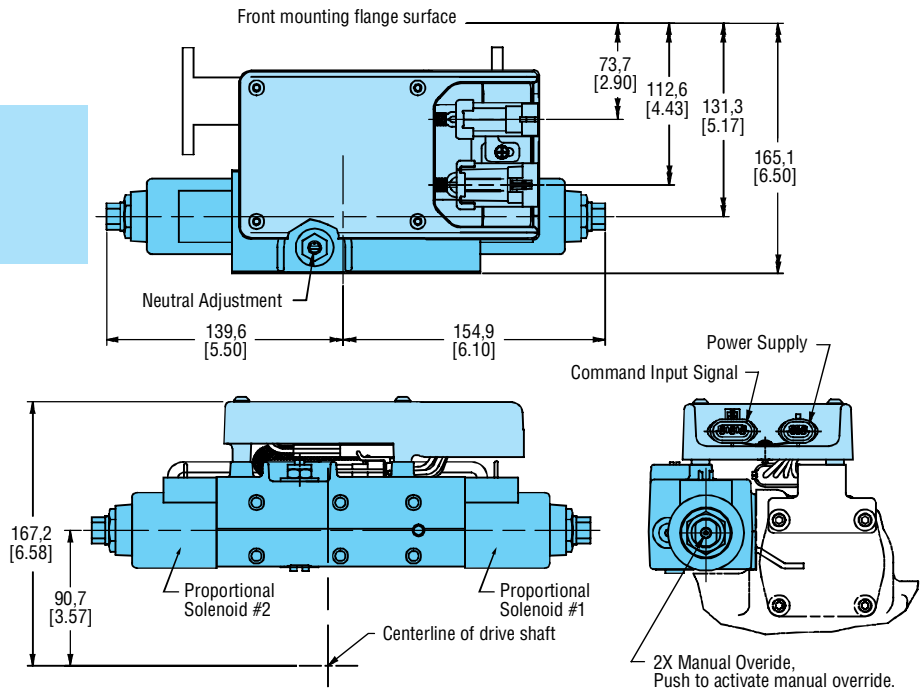

Note: In order to assure the most reliable installation and operation of any electronic control, proper installation methods should be followed with respect to interconnection wiring harness, command signal devices, fusing, and input power switching. Proper care should be taken to prevent damage to all electrical and electronic components due to abrasion, moving objects, heat, moisture or other environmental hazards. For safety critical applications, Eaton recommends that a switch be installed in line with (+ Battery) power to the module so that power may quickly be disconnected in case of emergency. A 2 ampere slow blow fuse should always be installed in the + battery line. It is recommended that during initial start-up and checkout, the machine be placed on jack stands to prevent inadvertent movement of the machine.

Command Input Signal	A (max)	B (min)	C	D (min)	E (max)
1 to 6 Vdc	1.5 Vdc	3.3 Vdc	3.5 Vdc	3.7 Vdc	5.5 Vdc
4-20 mA*	-20 mA	-4.5 mA	0 mA	+4.5 mA	+20 mA
±100 mA	-100 mA	-7.5 mA	0 mA	+7.5 mA	+100 mA

*Note: The +20 mA command input signal configuration operates the pumps in one direction. The customer has to change the polarity on the -20 mA signal to operate the pump in the opposite direction.

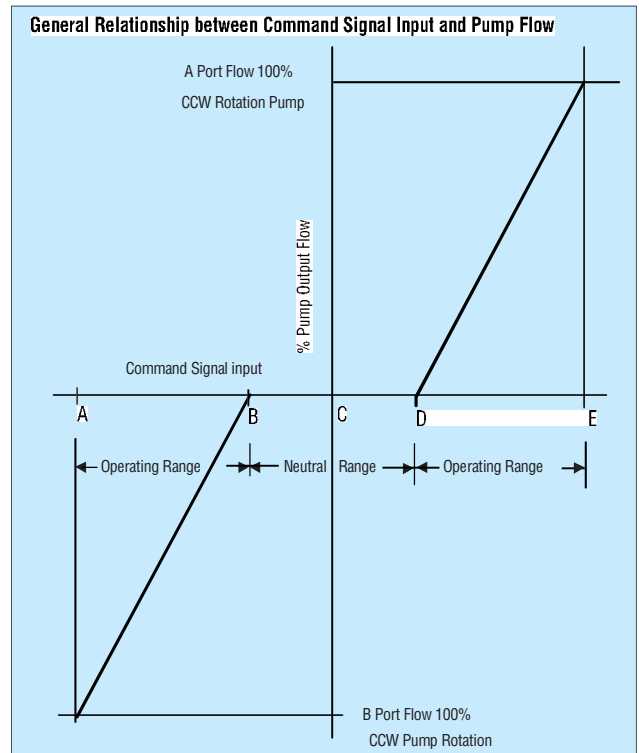

Model 72400

72400

Solenoid Operated Control

Code Position 16,17

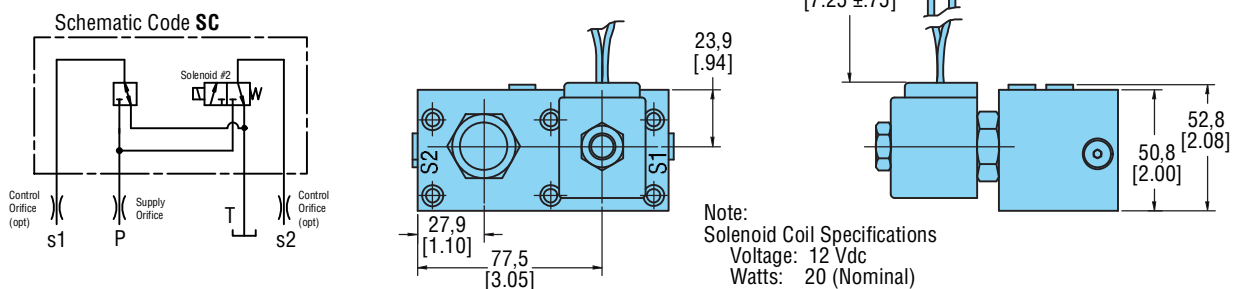
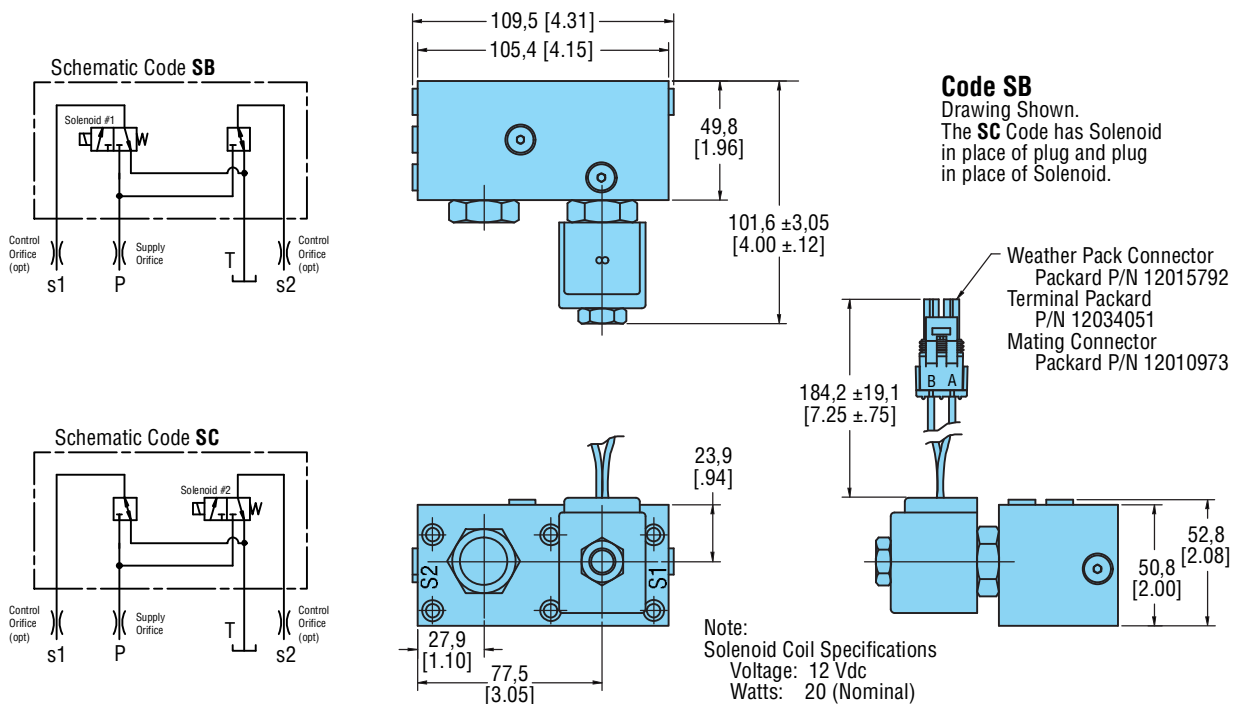
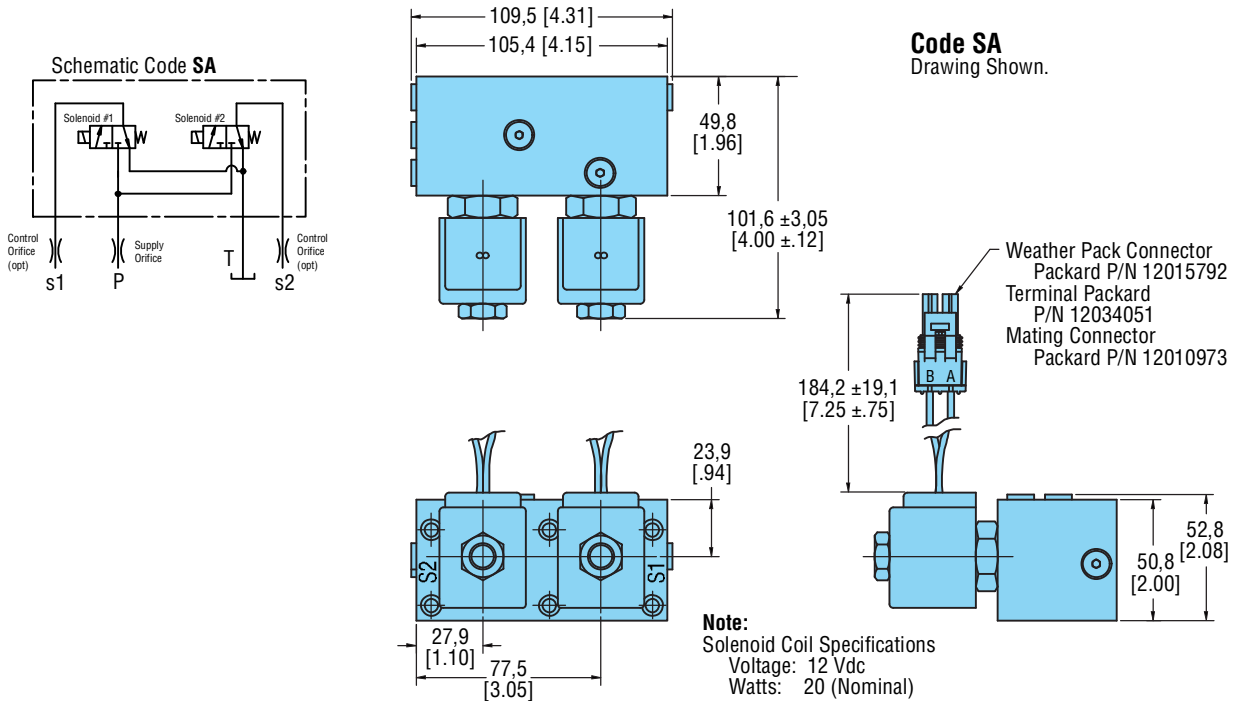

Model 72400

72400

Adjustable Displacement Limiter

Code Position 24, 25 and Selection BB

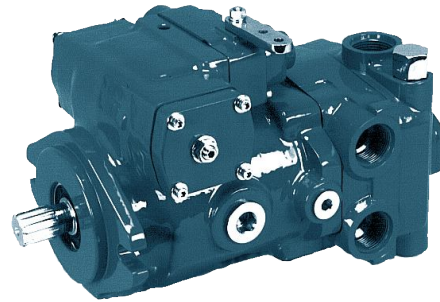

- Externally Adjustable Displacement
- Settings are Maximum Displacement of the Pump to Zero
- Independent Adjustment for Both Main Ports
- Field Adjustable
- Available in Kit Form (see page 62)

All factory units shipped with adjustable stops are set at maximum pump displacement.
See re-adjustment instructions below.

To Calculate Displacement Required

The displacement required divided by displacement of one turn of set screw equals the number of turns of set screw to obtain displacement.

Example for 3.00 in³/r re-adjustment:
 $2.0 \text{ in}^3/\text{r} \div .2854 \text{ in}^3/\text{r} =$
 7 turns of set screw

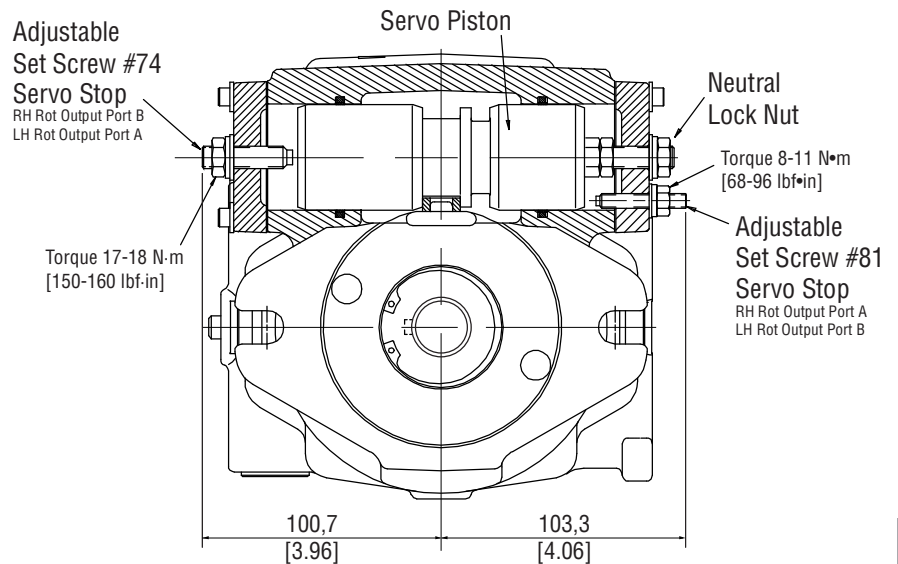

Displacement per Turn		
2.48 in ³ /r Pump Displacement @ Full Cam		
Turns of Set Screw	Item #81 Stop	Item #74 Stop
1	.2359 in ³ /r	.2022 in ³ /r
2	.47 in ³ /r	.40 in ³ /r
3	.71 in ³ /r	.61 in ³ /r
4	.94 in ³ /r	.81 in ³ /r
5	1.18 in ³ /r	1.01 in ³ /r
6	1.42 in ³ /r	1.21 in ³ /r
7	1.65 in ³ /r	1.42 in ³ /r
8	1.89 in ³ /r	1.62 in ³ /r
9	2.12 in ³ /r	1.82 in ³ /r
10	2.36 in ³ /r	2.02 in ³ /r
10.5	2.48 in³/r	2.13 in ³ /r
11	N/A	2.22 in ³ /r
12	N/A	2.43 in ³ /r
12.3	N/A	2.48 in³/r

Displacement per Turn		
2.48 in ³ /r Pump Displacement @ Full Cam		
Turns of Set Screw	Item #81 Stop	Item #74 Stop
1	.2359 in ³ /r	.2022 in ³ /r
2	.47 in ³ /r	.40 in ³ /r
3	.71 in ³ /r	.61 in ³ /r
4	.94 in ³ /r	.81 in ³ /r
5	1.18 in ³ /r	1.01 in ³ /r
6	1.42 in ³ /r	1.21 in ³ /r
7	1.65 in ³ /r	1.42 in ³ /r
8	1.89 in ³ /r	1.62 in ³ /r
9	2.12 in ³ /r	1.82 in ³ /r
10	2.36 in ³ /r	2.02 in ³ /r
10.5	2.48 in³/r	2.13 in ³ /r
11	N/A	2.22 in ³ /r
12	N/A	2.43 in ³ /r
12.3	N/A	2.48 in³/r

To Re-Adjust Displacement

- 1 Loosen nut on adjustable set screw #81 servo stop. Screw stop in until it touches the servo piston. Back the screw out (number of turns required) to obtain the flow required. Refer to chart for displacements. Lock adjustment with nut. Torque nut 8 to 11 N•m [68 to 96 lbf•in].
- 2 Loosen nut on adjustable set screw #74 servo stop. Screw stop in until it touches the servo piston. Back the screw out (number of turns required) to obtain the flow required. Refer to chart for displacements. Lock adjustment in place with nut. Torque nut 17 to 18 N•m [150 to 160 lbf•in].

Metric Conversion: Displacement in³/r X 16.387 = cm³/r

72400 Adjustable Displacement Limiter Kits

Field Installed Kits

One side Kit #72400-938

Two sides Kit #72400-940

Disassembly

- 1 Remove the four cap screws (Item #7) and washers (Item #61) retaining the existing cover plate (Item #11) opposite neutral set screw.
- 2 After removing existing cover plate (Item #11) and cover gasket, measure the distance from the servo piston to the surface of housing for reference for neutral setting.
- 3 Remove neutral setting nut (Item #2).
- 4 Remove the four cap screws retaining the existing cover plate (Item #17).
- 5 The cover plate (Item #17) is screwed onto the servo piston bolt. When removing the cover plate, count the amount of turns it takes to remove cover for reassembly. Also remove existing gasket (Item #12).

Installing Servo Stops

- 1 Place new gasket (Item #12) onto the housing on the neutral setting screw side of the servo piston. Hold in position with a small amount of petroleum jelly.
- 2 Screw new cover plate (Item #17) onto servo piston bolt the same number of turns as it took to remove it. Install the four cap screws (Item #7) and washers (Item #61) to retain cover plate. Torque 4,5 to 5,4 N-m [40 to 48 lbf-in].
- 3 Install seal washer (Item #6), washer (Item #60) and jam nut (Item #2). Torque nut 17 to 18 N-m [150 to 160 lbf-in]. At this time, check the distance from the servo piston to housing surface on opposite side. It should be the same as previously measured at disassembly. If not the same, loosen jam nut and with a hex key wrench, adjust and re-torque nut.
- 4 Install new cover plate (Item #11) and retain with four cap screws (Item #7) and washers (Item #61). Torque 4,5 to 5,4 N-m [40 to 48 lbf-in].
- 5 Insert adjustable servo stop set screw (Item #81) in until it touches the servo piston. Back the screw out to obtain the flow required. Refer to chart for displacements. Lock adjustment into place with seal washer (Item #83), washer (Item #82), and jam nut (Item #80). Torque nut 8 to 11 N-m [68 to 96 lbf-in].
- 6 Insert adjustable servo stop set screw (Item #74) in until it touches the servo piston. Back the screw out to obtain the flow required. Refer to chart for displacements. Lock adjustment into place with seal washer (Item #6), washer (Item #60), and jam nut (Item #2). Torque nut 17 to 18 N-m [150 to 160 lbf-in].

Adjustable Servo Stop Kit Parts			Kit #72400-938	Kit #72400-940
Item #	Part Number	Description	Qty.	Qty.
2	16024-6	Jam Nut	1	2
6	16254-6	Seal Washer	1	2
11	72400-651	Cover Plate	1	1
12	72400-621	Cover Gasket	1	2
17	72400-771	Cover Plate		1
60	16254-26	Washer	1	2
74	16139-624	Set Screw	1	1
80	16022-4	Jam Nut		1
81	16139-424	Set Screw		1
82	16254-24	Washer		1
83	16254-4	Seal Washer		1

Model 72400

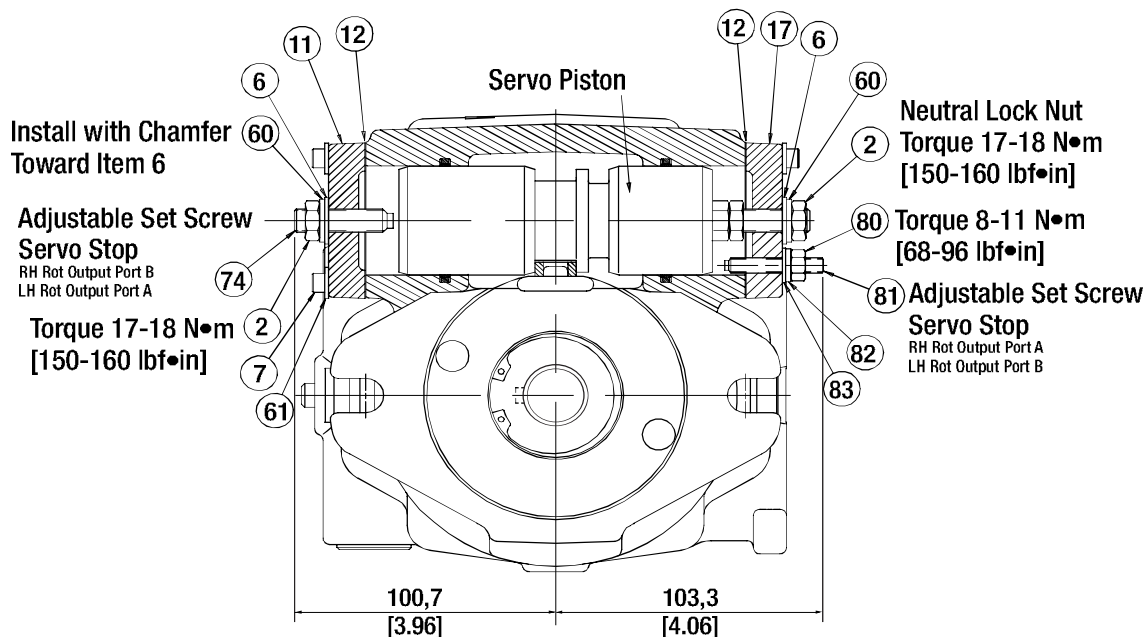

72400

Supply and Control Orifice

Code Position 19 and 20

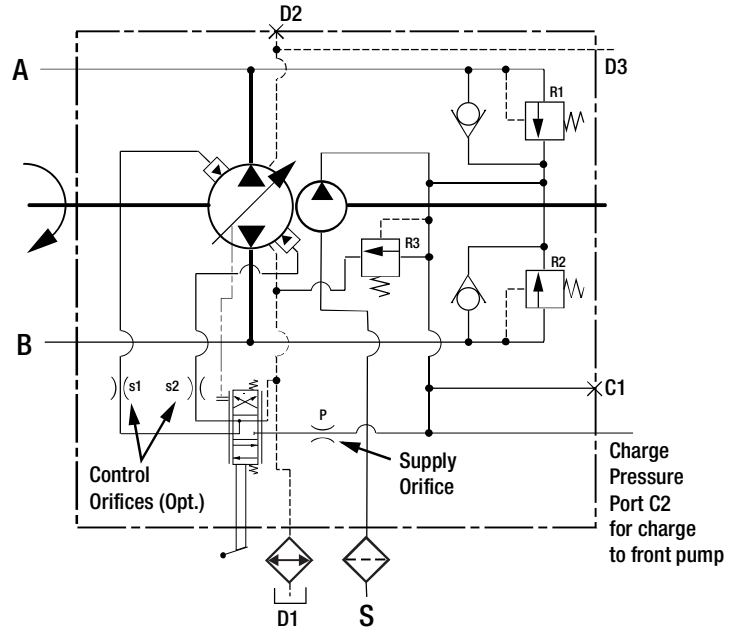
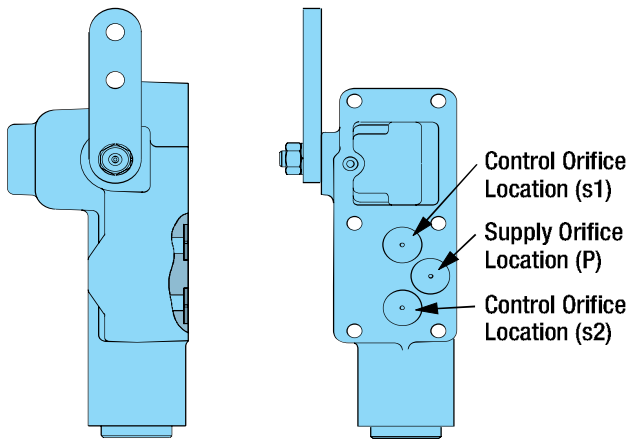

Calculated Time from Neutral to Full Stroke (seconds)

Supply Orifice Size mm [in]	Control Orifice Size, mm [in]							
	0,71 [0.028]	0,81 [0.032]	0,91 [0.036]	1,02 [0.040]	1,12 [0.044]	1,32 [0.052]	1,45 [0.057]	None
0,71 [0.028]	1.245	1.148	1.085	1.043	1.015	0.983	0.972	0.946
0,81 [0.032]	1.199	1.089	1.013	0.961	0.925	0.881	0.866	0.828
0,91 [0.036]	1.173	1.053	0.968	0.907	0.863	0.808	0.788	0.736
1,02 [0.040]	1.157	1.031	0.939	0.871	0.821	0.756	0.731	0.662
1,12 [0.044]	1.147	1.017	0.920	0.847	0.792	0.718	0.688	0.602
1,32 [0.052]	1.136	1.001	0.899	0.820	0.758	0.670	0.633	0.510
1,45 [0.057]	1.133	0.996	0.892	0.810	0.745	0.652	0.611	0.465
1,65 [0.065]	1.129	0.991	0.885	0.801	0.734	0.634	0.589	0.408
1,85 [0.073]	1.128	0.988	0.881	0.796	0.727	0.624	0.576	0.364
None	1.125	0.984	0.875	0.787	0.716	0.606	0.553	0.138

Note: Proper orifice selection must be determined by actual testing.

Model 72400