



Transmission Pumps

TA15 Series-10 Design

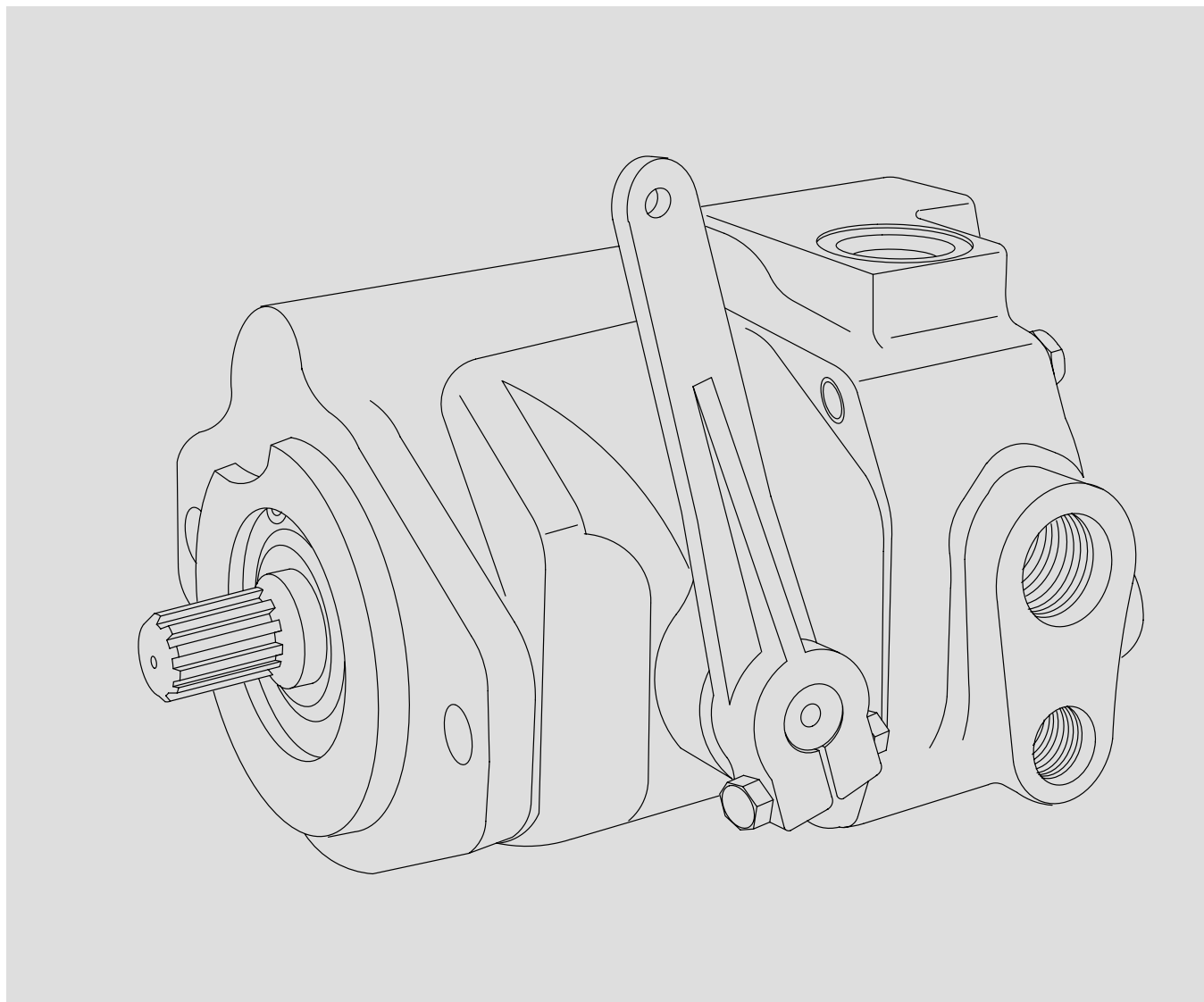

Table of Contents

Section	Page
I. Introduction	3
A. Purpose of Manual	3
B. Model Codes	3
C. Description	3
D. Table I - Model Code Breakdown	3
II. Principles of Operation	5
A. Gerotor Pump Unit Operation (Replenishing Pump)	5
B. In-Line Piston Pump Unit Operation	6
III. General Overhaul Procedures	7
IV. Disassembly	8
V. Inspection and Repair	16
VI. Assembly	17
A. Piston Pump	17
VII. Start-Up After Repair	17
VIII. General Maintenance	18
A. Lubrication	18
B. Replacement Parts	18
C. Adjustments	18
D. Adding Fluid to the System	18
E. Oil Filter	18
F. Troubleshooting	18
IX. Trouble, Cause, and Remedy Information	19
A. General	19
B. Transmission Making Excessive Noise	19
C. Hydraulic Transmission Overheating	19
D. System Not Developing Pressure	19
E. External Leakage	20
F. Miscellaneous	20
G. Trouble, Cause, and Remedy Chart	21

Section I - Introduction

A. Purpose Of Manual

This manual describes the basic operational characteristics and provides service and overhaul information for the Vickers TA15 series hydrostatic variable displacement inline piston pump.

B. Model Codes

The many variations within each basic model series are covered in the model codes identifying these units. Service inquiries should always include the complete unit model number, which is stamped on the name plate.

See Table 1 for a complete breakdown of the codes covering the TA15 series hydrostatic pump.

C. Description

The assembly and A.S.A. schematic diagram of the hydrostatic pump is shown in Figure 1. The major components of the units are: the housing, drive shaft, rotating group, swash plate, valve plate, and a yoke.

The valve plate subassembly also serves as the back cover of the entire unit and includes the gerotor pump components, the replenishing relief valves, and the inlet and outlet ports. A bearing in the cover and one in the housing support the drive shaft.

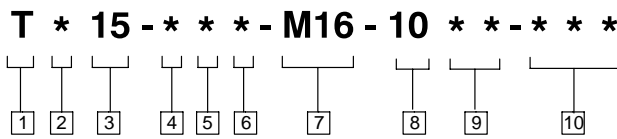

<p>1 Transmission Unit</p> <hr style="border: 0; border-top: 1px solid black; margin-top: 5px;"/>	<p>5 Pump or Motor Control Options 1 - Splined Shaft 2 - Straight Key Shaft</p> <hr style="border: 0; border-top: 1px solid black; margin-top: 5px;"/>	<p>8 Design Number</p> <hr style="border: 0; border-top: 1px solid black; margin-top: 5px;"/>
<p>2 Component Function</p> <hr style="border: 0; border-top: 1px solid black; margin-top: 5px;"/>	<p>6 Pump or Motor Control Description</p> <hr style="border: 0; border-top: 1px solid black; margin-top: 5px;"/>	<p>9 Rotation - Viewed from Shaft End</p> <hr style="border: 0; border-top: 1px solid black; margin-top: 5px;"/>
<p>3 Pump or Motor Frame Size</p> <hr style="border: 0; border-top: 1px solid black; margin-top: 5px;"/>	<p>7 Minimum Displacement Designation for Variable Motors</p> <hr style="border: 0; border-top: 1px solid black; margin-top: 5px;"/>	<p>10 Special Features Suffix</p> <hr style="border: 0; border-top: 1px solid black; margin-top: 5px;"/>
<p>4 Pump or Motor Shaft Extension Options</p>		

Table 1. Model Code Breakdown

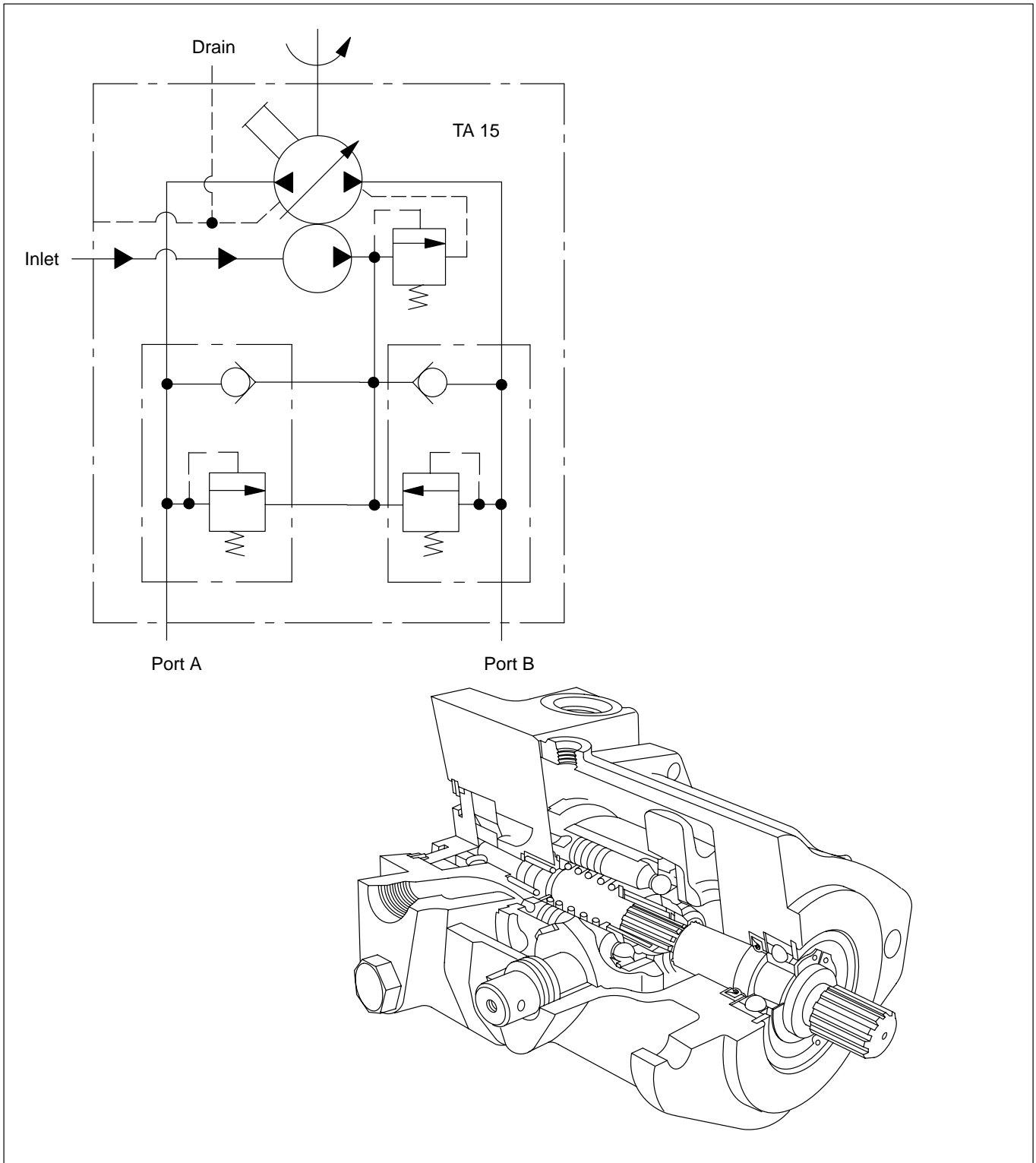

Figure 1.

Section II - Principles of Operation

A. Gerotor Pump Unit Operation (Replenishing Pump)

The gerotor pump mechanism consists of a pair of gear-shaped elements, one within the other, mounted in a pump chamber. The inner gear is directly connected to the shaft, and itself drives the outer gear.

The inner gear has one fewer teeth than the outer gear. The tooth form of each gear is related to that of the other in such a way that each tooth of the inner gear is always in sliding contact with the surface of the outer gear. Each meshing pair of teeth of the two gears definitely engages at just one place in the pump.

At one side of the point of mesh, pockets of increasing size are formed as the gears rotate, while on the other side the pockets decrease in size. The pockets of increasing size are suction pockets while those of decreasing size are discharge pockets. In Figure 2, it will be noted that the pockets on the right hand side of the drawings are increasing in size as one moves down the figure, while those on the left hand side are decreasing in size. The intake side of the replenishing pump is at the top, and the discharge is at the bottom of this illustration.

The two gears travel slowly with respect to each other, even though the shaft is rotating rapidly.

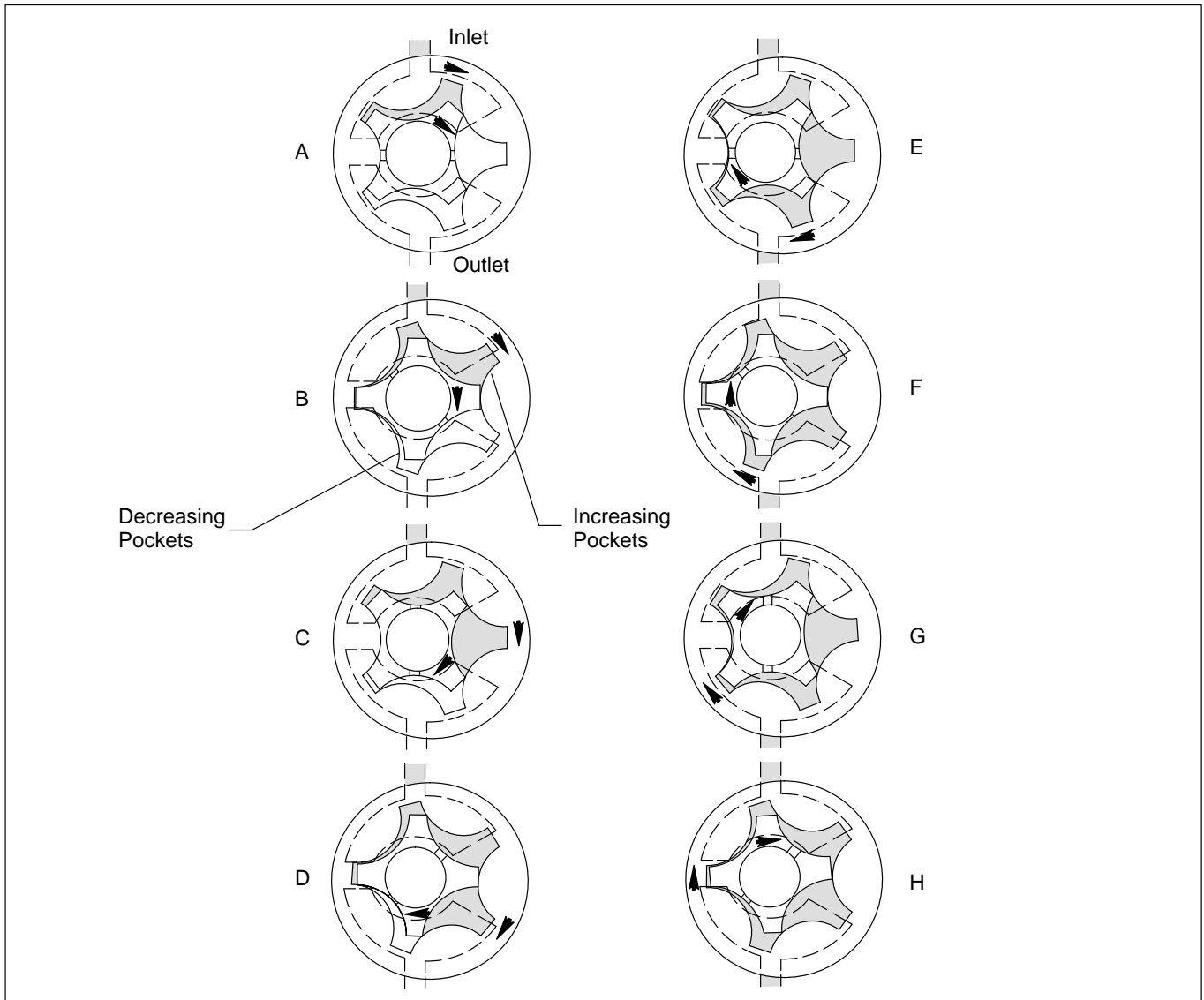

Figure 2.

B. In-Line Piston Pump Unit Operation

Rotation of the drive shaft imparts a reciprocating motion to the pistons with respect to their cylinder block bores, as a result of the angularity between the axis of rotation of the drive shaft and the plane of the piston shoe bearing surface on the swash plate (see Figure 3). Each piston reaches two dead-center positions in one revolution or cycle.

As the piston revolves past the bottom dead-center position (when the piston is nearest the valve plate), it begins to withdraw from the cylinder block bores and thus begins its intake or suction stroke. During that intake stroke of the

piston, fluid is drawn into the corresponding cylinder block bore through a porting arrangement located on the face of the valve plate and cylinder block.

As the piston reaches top dead-center (when the piston is furthest from the valve plate) its withdrawing motion ceases, ending the intake stroke. This point is 180° from bottom dead-center. Further rotation of the cylinder block, and piston, creates a return motion of the piston towards the valve plate and thereby establishes the discharge stroke of the piston. During the discharge stroke, fluid is expelled from the cylinder block bore through the outlet port of the valve plate in a reverse manner to the intake stroke.

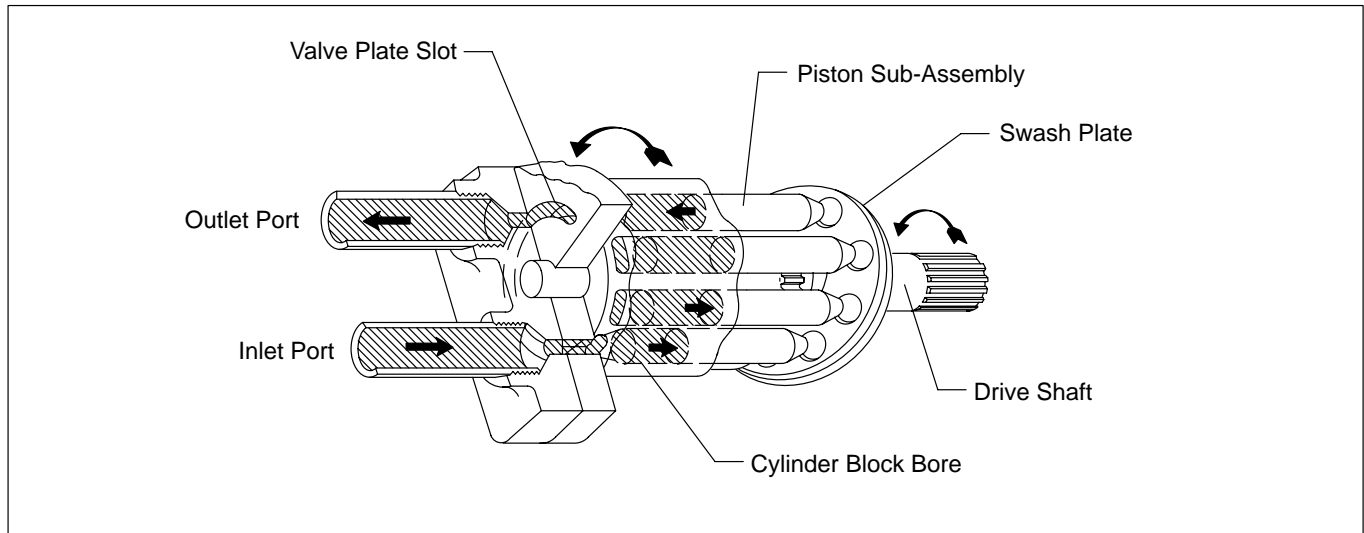

Figure 3.

When the piston reaches bottom dead-center, axial piston motion ceases, and the discharge stroke is ended. The pumping cycle described above is made by each piston as it and the cylinder block are revolved through 360°.

The pumps turn in one direction by the engine and can deliver oil to the propelling motor through either of its ports (A or B).

Variable displacement is effected by altering the angularity between the swash plate and the drive shaft axis as shown by views A,B, and C in Figure 4. The amount of angular movement of the swash plate (i.e. displacement change) is determined by control lever position.

When the yoke is straight across at right angle to the center line of the pump, there is no flow (refer to Figure 4, view B). When the yoke is moved to an extreme angular position, maximum pump delivery will result through one of the ports (View A). Moving the yoke over center to an extreme angular position (View C) on the opposite side of the pump will result in maximum oil delivery through the opposite port. By changing the position of the yoke from one side to the other, the oil flow path changes to the motor.

Since either port of a cross center pump can be inlet or outlet, replenishing relief valves are required to provide access to relief valve protection (See Figure 5).

Some fluid is constantly being lost from the system; this fluid is replenished by use of the replenishing pump. Fluid is drawn into the replenishing pump inlet from the reservoir by atmospheric pressure. It discharges from this pump to a common passage. When the piston pump delivery is directed to ports A or B, the replenishing fluid overcomes the 10 psi spring setting and discharges into the inlet passage of the piston pump at a pressure in excess of 10 psi (see Figure 5).

Any excess pressure in the common passage empties over the 25 psi relief valve into the pump housing and back to the reservoir. The 25 psi relief valve consists of a poppet and spring. Pressure acts directly on the poppet against the spring.

To take care of pressure surges in the outlet passage, relief valve action is provided. The replenishing and relief valve cartridges are pre-set and pre-tested at the factory. The cartridges pressure adjustments cannot be changed in the field. The outer shell of these cartridges is made of hexagon stock to provide a fluid passage.

The cartridge relief valve operates when the outlet pressure on the end of the pin creates a force greater than the pilot spring force (4500 psi) and unseats the inner poppet. The unseating of the poppet reduces pressure in the 20 psi spring chamber to a point where the outer poppet moves, thus discharging excess pressure to the relief cavity and to the reservoir.

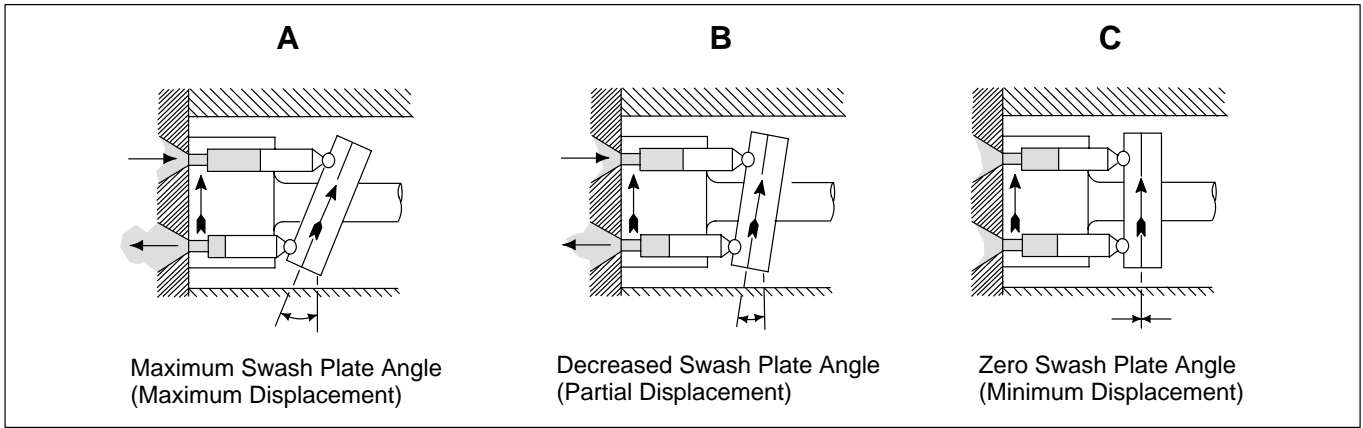

Figure 4.

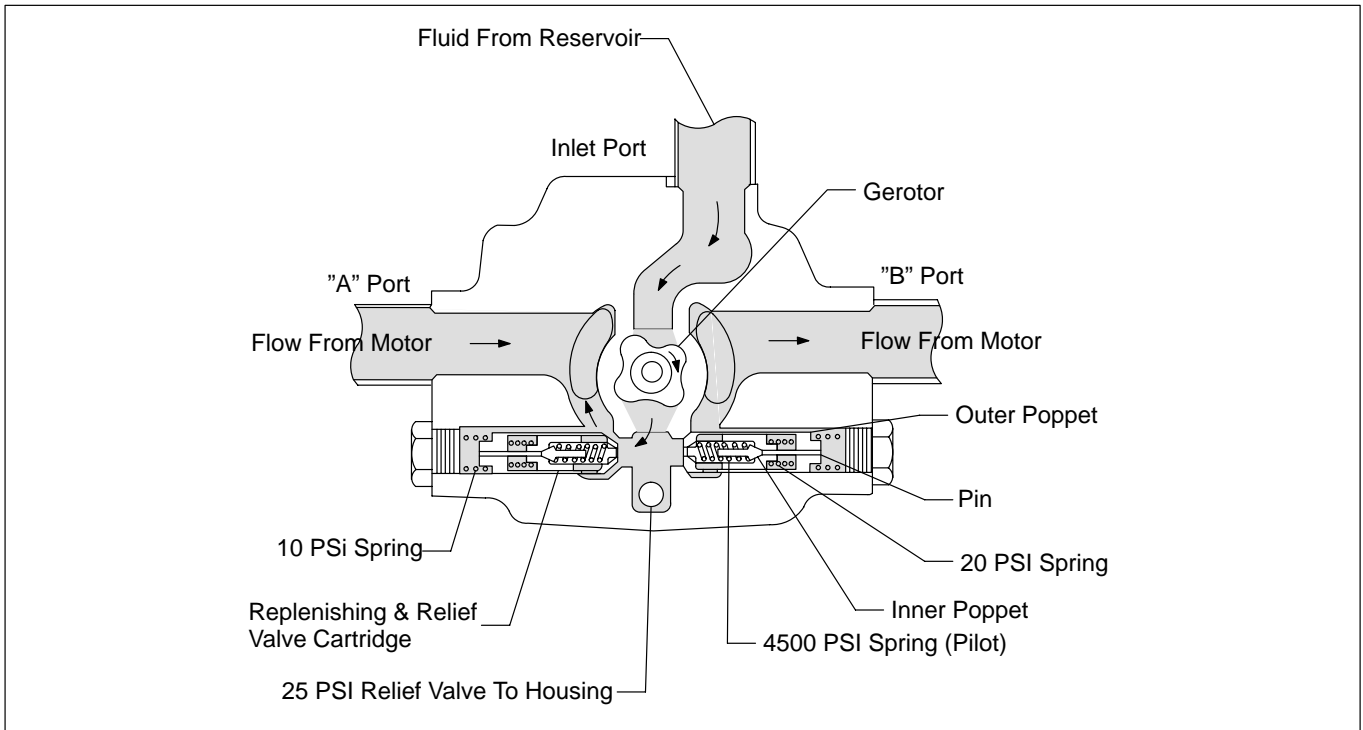

Figure 5.

Section III - General Overhaul Procedures



CAUTION

*Block vehicle if it is on a slope. The hydraulic transmission **cannot** act as a parking brake.*

Before breaking a circuit connection, make certain that the power is off and the system pressure has been released.

Lower all vertical cylinders, discharge all accumulators, and block any load whose movement could generate pressure.

Completely drain the oil from the vehicle hydraulic system. discard this oil and use **new, clean** oil when restoring the unit to service.

After removing the hydrostatic pump from the vehicle, and before disassembly, cap or plug all ports and disconnected hydraulic lines, and clean out the outside of the unit thoroughly to prevent entry of dirt into the system.



CAUTION

Absolute cleanliness is essential when working on a hydraulic system. Always work in a clean area. The presence of dirt and foreign materials in the system can result in serious damage or inadequate operation.

Section IV - Disassembly

The following tools for overhauling the TA15 pump are shown in Figure 6.

All models are disassembled in the same general sequence as shown in the exploded view Figure 7.

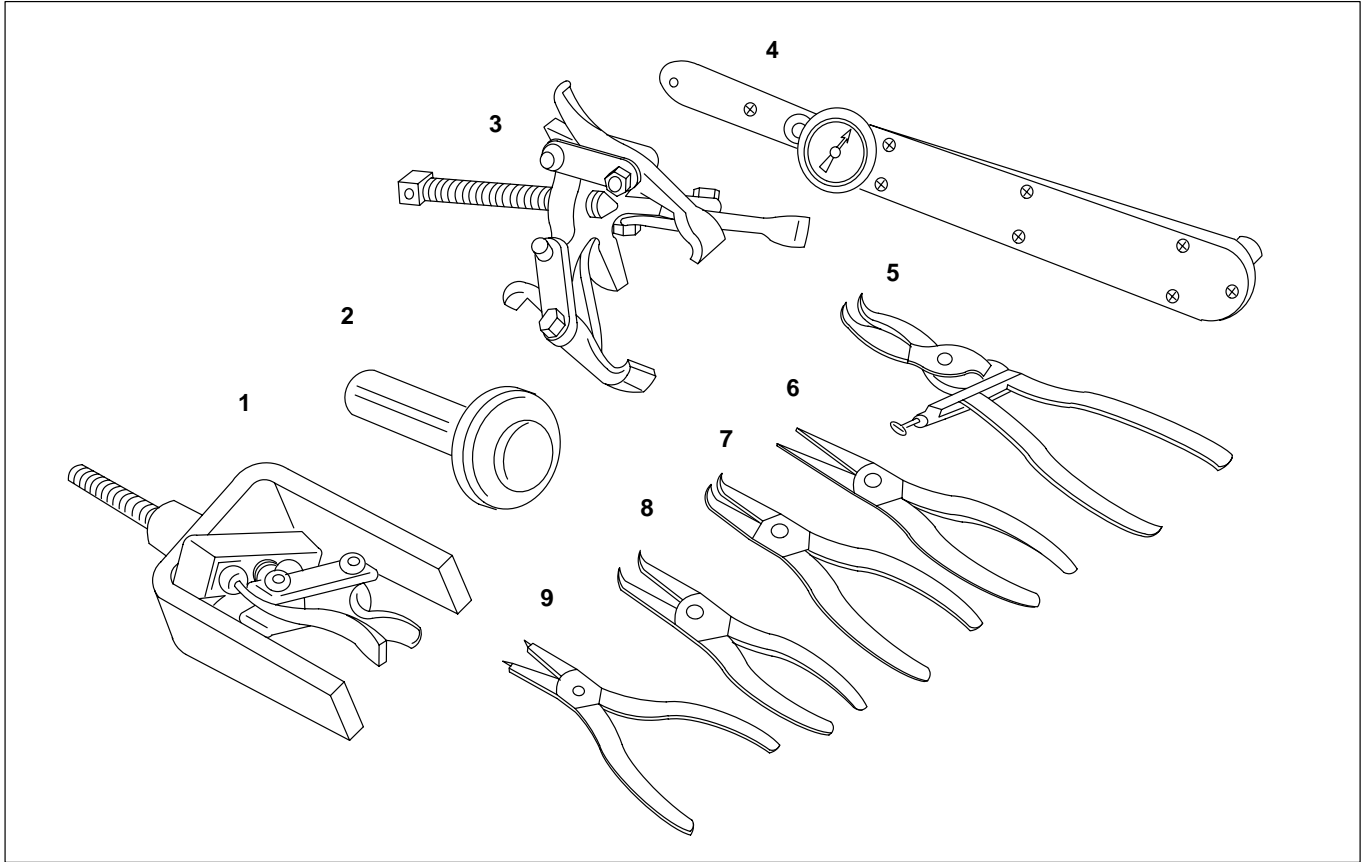
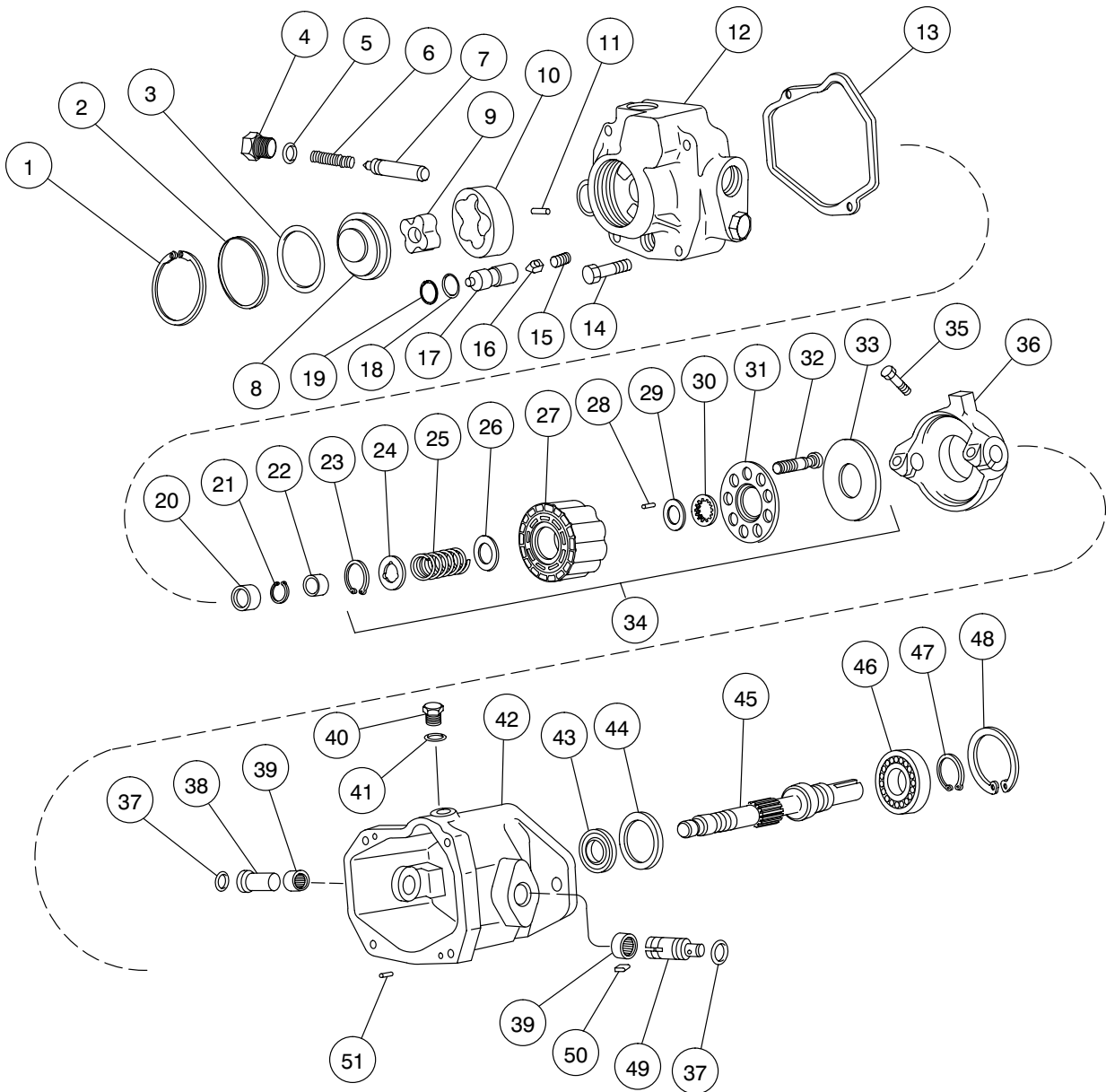

Figure 6.

1. Bearing puller
2. Shaft seal driver
3. Bearing puller
4. Torque wrench (150 ft-lb)
5. No. 5 Truarc (90°) pliers
6. No. 24 Truarc (straight) pliers
7. No. 23 Truarc (90°) pliers
8. No. 22 Truarc (90°) pliers
9. No. 21 Truarc (straight) pliers



- 1. Snap Ring
- 2. Washer
- 3. "O" Ring
- 4. Plug
- 5. "O" Ring
- 6. Spring
- 7. Plunger Valve
- 8. End Plate
- 9. Inner Rotor
- 10. Outer Rotor
- 11. Pin
- 12. Valve Plate
- 13. Gasket
- 14. Screw
- 15. Spring
- 16. Poppet
- 17. Plug

- 18. "O" Ring
- 19. Snap Ring
- 20. Bearing
- 21. Retaining Ring
- 22. Sleeve
- 23. Snap Ring
- 24. Washer
- 25. Spring
- 26. Thrust Washer
- 27. Cylinder Block
- 28. Pin
- 29. Washer
- 30. Spherical Washer
- 31. Shoe Plate
- 32. Piston Kit
- 33. Swash Plate
- 34. Rotating Group Kit

- 35. Screw
- 36. Yoke
- 37. "O" Ring
- 38. Pintle
- 39. Bearing
- 40. Plug
- 41. "O" Ring
- 42. Housing
- 43. Shaft Seal
- 44. Spacer
- 45. Shaft
- 46. Bearing
- 47. Snap Ring
- 48. Snap Ring
- 49. Control Pintle
- 50. Key
- 51. Pin

Figure 7.

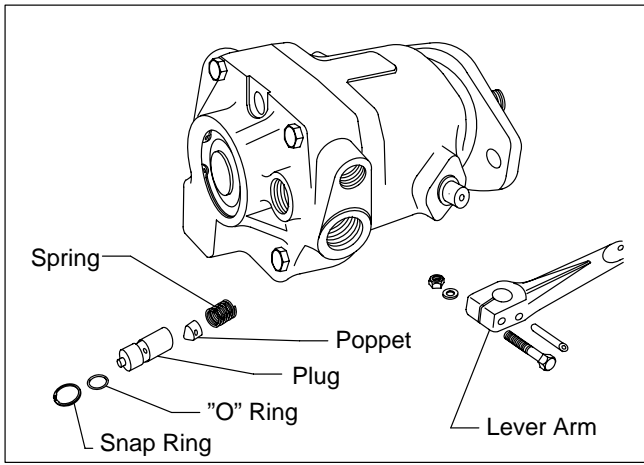

Step 1.

1. In this first view of the pump, the lever arm has been removed from the control pintle. This pintle governs the movement of the yoke inside the pump which, in turn, allows variable displacement to occur, depending on the position or angle of the yoke in respect to the shaft axis.

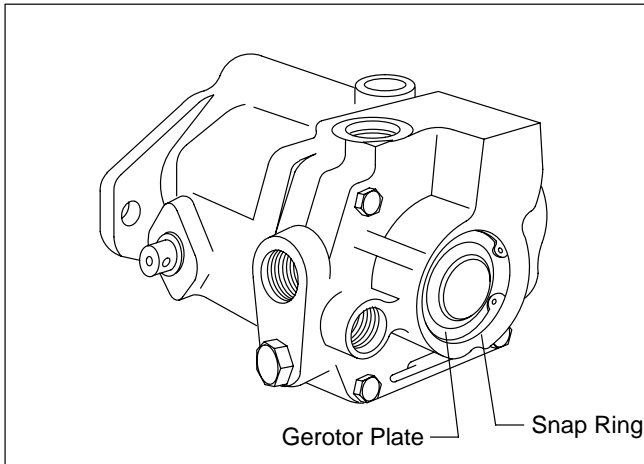

Step 2a.

2a. **End Plate and Gerotor** - Clamp pump mounting flange in a machinist's vise, being certain to use protective jaws. Remove end plate, snap ring, and washer.

Remove the relief valve snap ring and lift out the plug, poppet, "O" Ring, and spring from the valve plate.

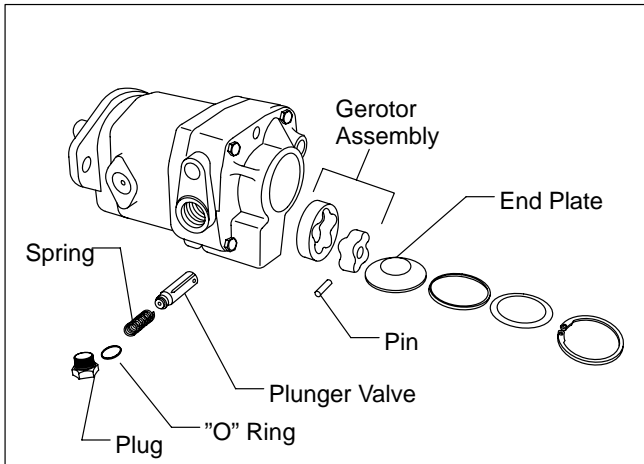

Step 2b.

2b. Separate the end plate from the valve plate. Remove the gerotor assembly and pin.

Remove the relief and replenishing valve plugs. Carefully slide out the springs and plunger valve cartridge.

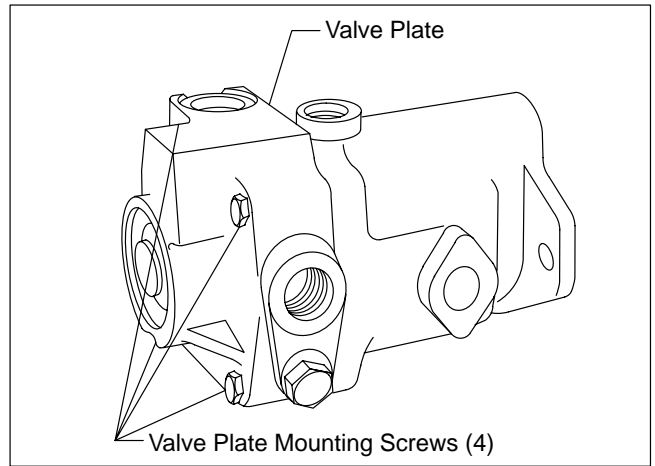

Step 3.

3. **Valve Plate** - Remove the four valve-plate mounting screws. Carefully remove the valve plate from the unit.

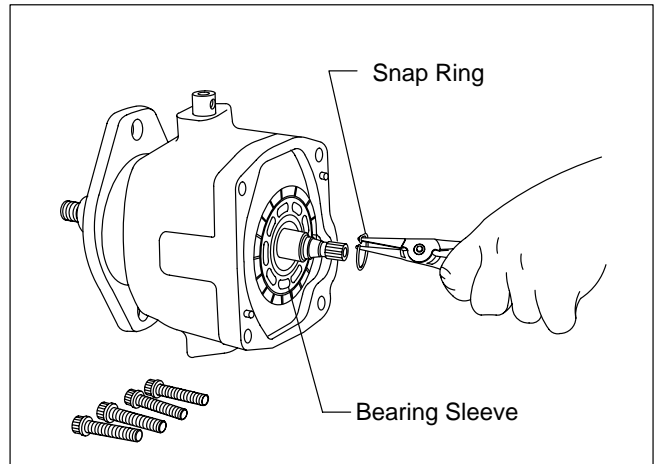

Step 4.

4. To begin removal of the rotating group, first remove the snap ring that holds the bearing sleeve on the shaft. Use snap ring pliers to accomplish this.

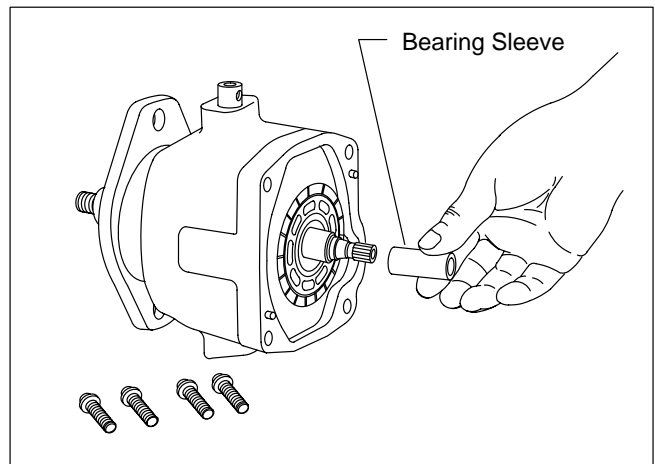

Step 5.

5. Next, slide the bearing sleeve off the shaft.

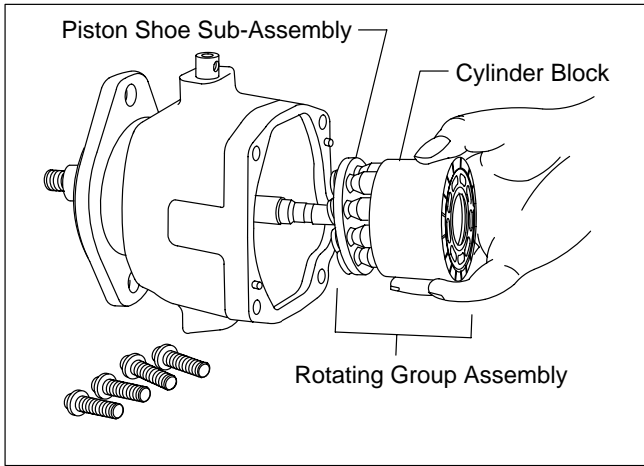

Step 6.

6. Now carefully remove the rotating group assembly, which consists of the cylinder block and piston shoe subassembly.

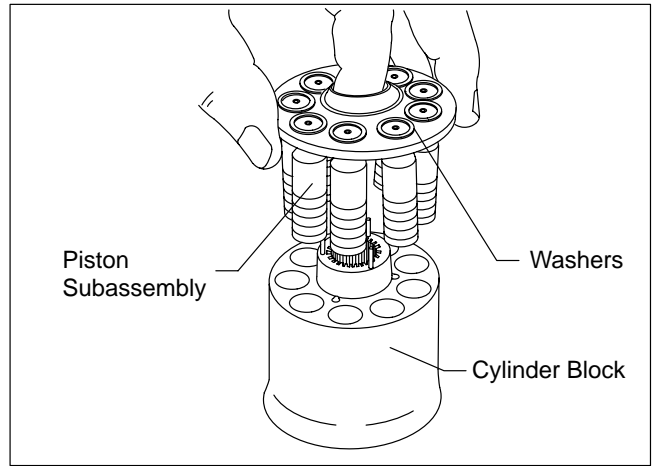

Step 8.

8. Remove piston subassembly from the cylinder block by lifting straight up, still holding washer in place with your index finger.

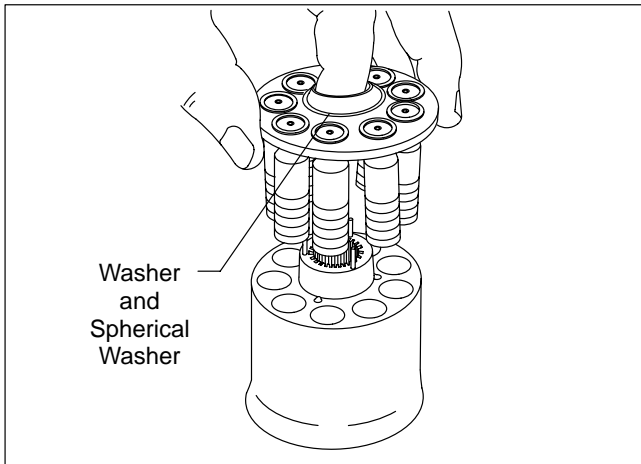

Step 7.

7. Place rotating group on a clean surface, being careful not to drop or scratch the running surface of the assembly. Then, as shown, hold washer and spherical washer in place with your index finger.

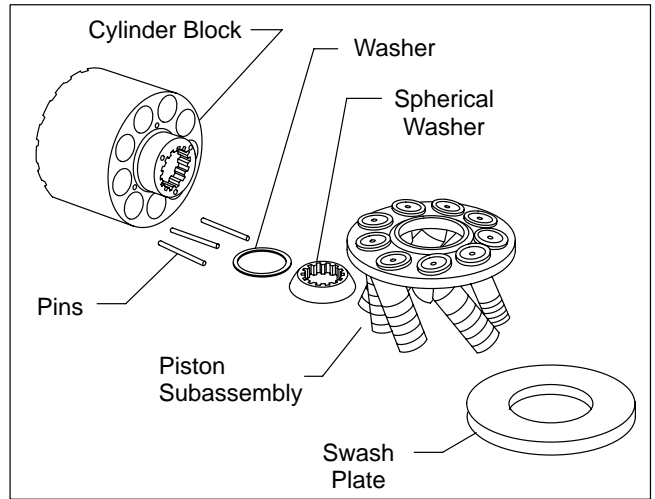

Step 9.

9. Then continue disassembly of the rotating group in the sequence illustrated here.

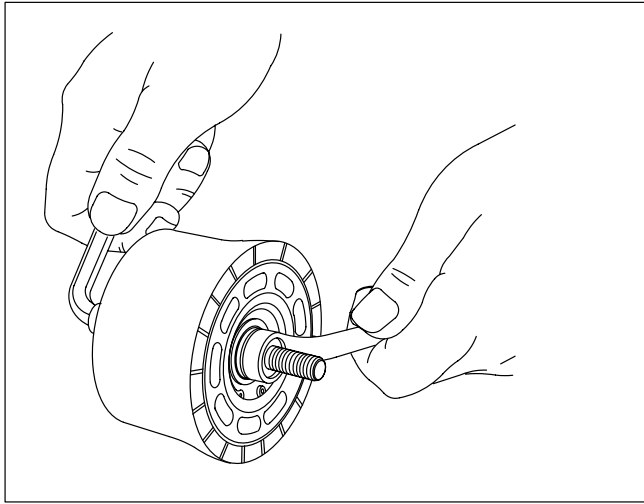

Step 10.

10. The cylinder block subassembly includes a heavy spring. To avoid injury, use the following special method of relieving spring tension before slipping the spring out of the block.



WARNING

The cylinder block subassembly includes a **heavy** spring. **To avoid injury**, use the following special method of relieving spring tension before slipping the spring out of the block.

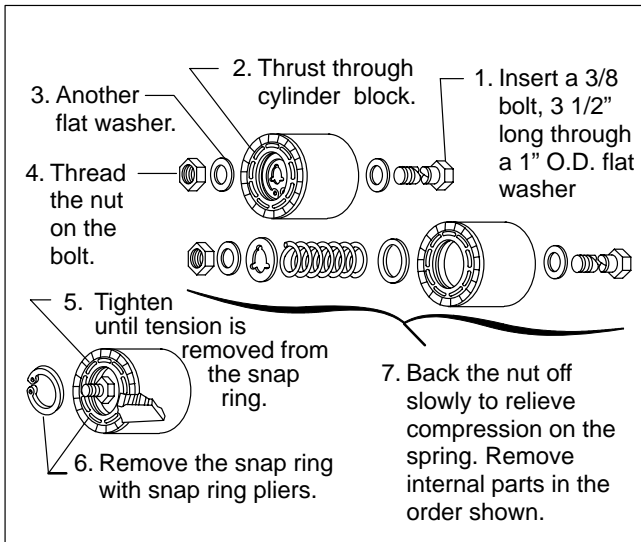

Step 11.

11. To relieve the spring tension, use a bolt, nut, and two washers as shown in this figure.

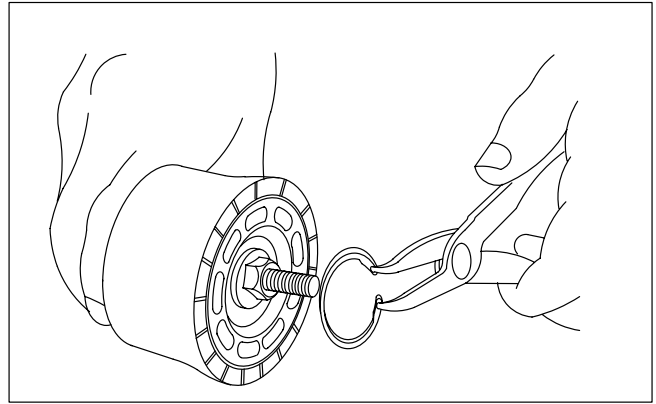

Step 12.

12. The spring is now compressed and held firmly and safely in place.

Remove the snap ring from the cylinder block with Truarc snap ring pliers; then relieve the tension of the spring by gradually unscrewing the nut from the special bolt, washer, and nut in the cylinder block.

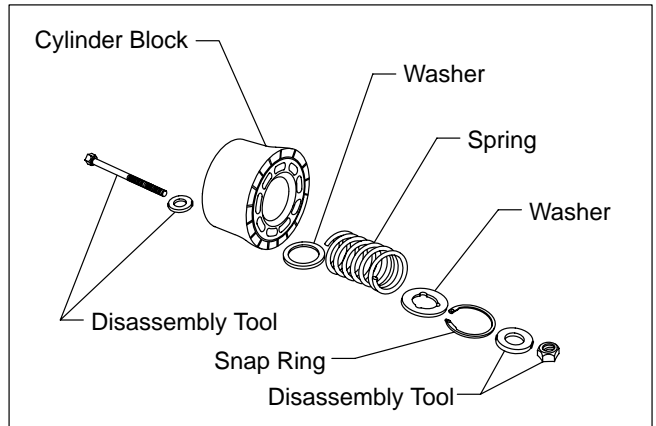

Step 13.

13. In this photograph, the cylinder block is shown completely disassembled and in the proper sequence. The bolt and washer at the extreme right and the nut and washer at the left are the disassembly "tools", and not a part of the cylinder block subassembly.

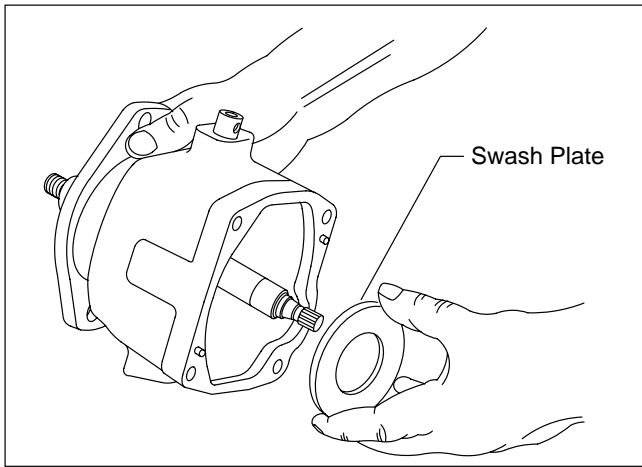

Step 14.

14. To accomplish the next step in the disassembly procedure, removing the swash plate, rotate the plate and pull out evenly from the yoke.

When assembled, the swash plate rests in a recess of the yoke and can be freely rotated with the finger tips; however, removal may be difficult due to oil suction under the plate.

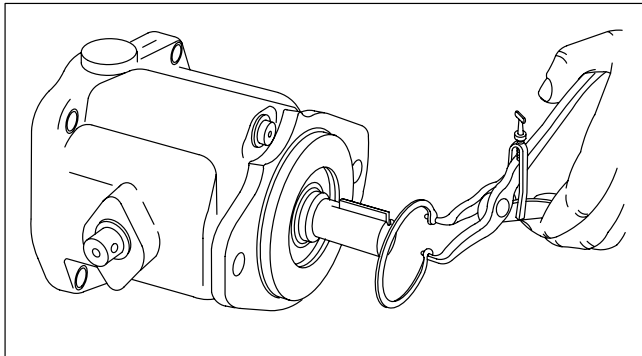

Step 15.

15. Now to remove the shaft. First, remove the snap ring retainer next to the bearing.

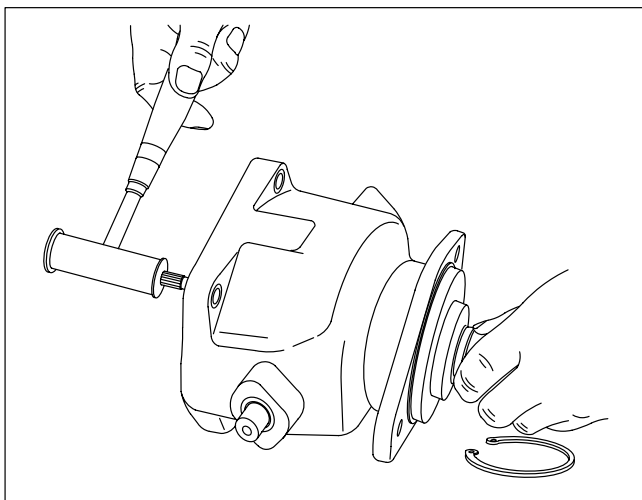

Step 16.

16. After the snap ring retainer is out, tap the shaft on the small end with a plastic-tip hammer for proper removal.

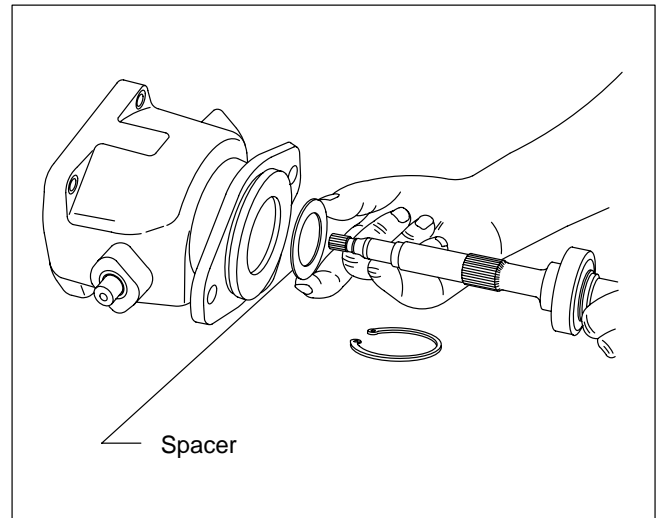

Step 17

17. Remove spacer that fits between the bearing and shaft seal.

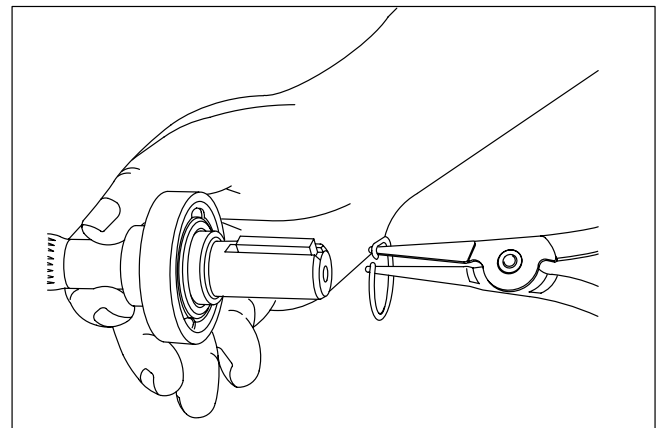

Step 18.

18. Using snap ring pliers, take off the large snap ring next to the bearing on the shaft.

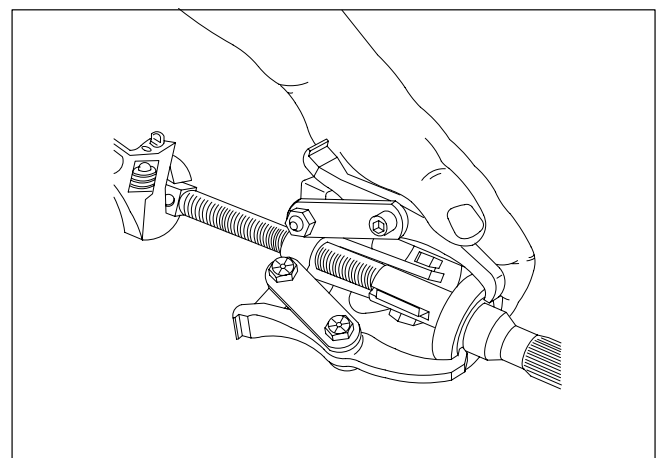

Step 19.

19. Then remove the bearing with a bearing puller (or arbor press, if available). **Any other method of bearing removal may damage the bearing.**

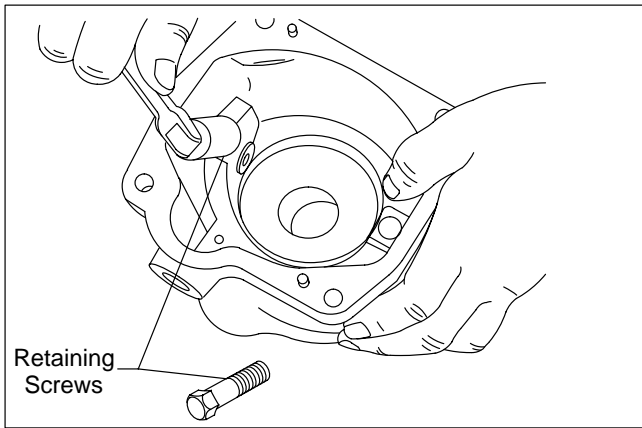

Step 20.

20. After the shaft has been removed, the pintles and yoke may be removed. To remove the pintles, begin by removing the retaining screws from the yoke.

The housing containing the yoke should be held firmly in a vise or secured to the valve plate when removing the yoke screws because of the torque.

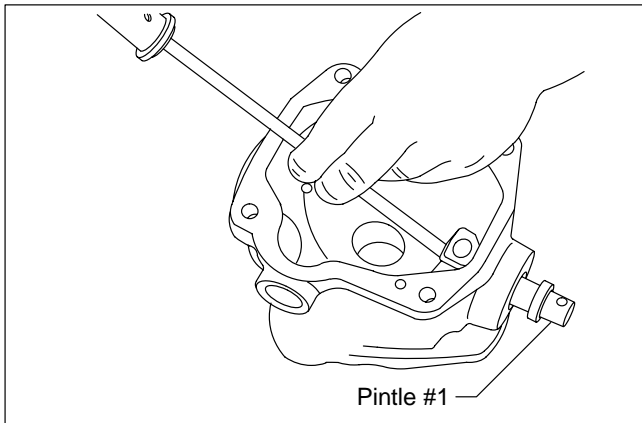

Step 21.

21. Now you will be able to take out the pintles. To do this, use a hammer and a brass rod 3/8 inch in diameter and about 10 inches long; tap out pintle #1 as shown here.

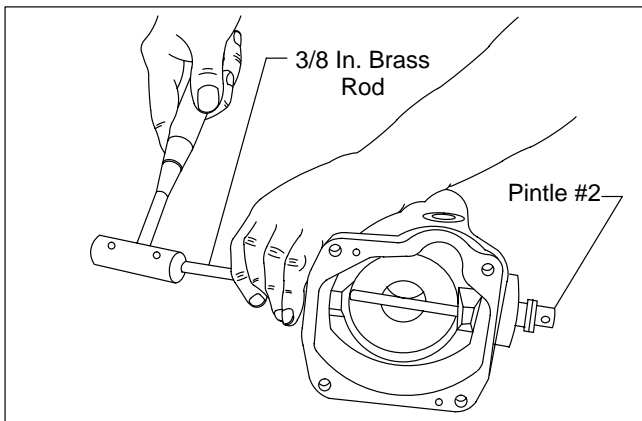

Step 22.

22. Pintle #2 is then easily removed by inserting the brass rod through the hole vacated by pintle #1 and tapping it out.

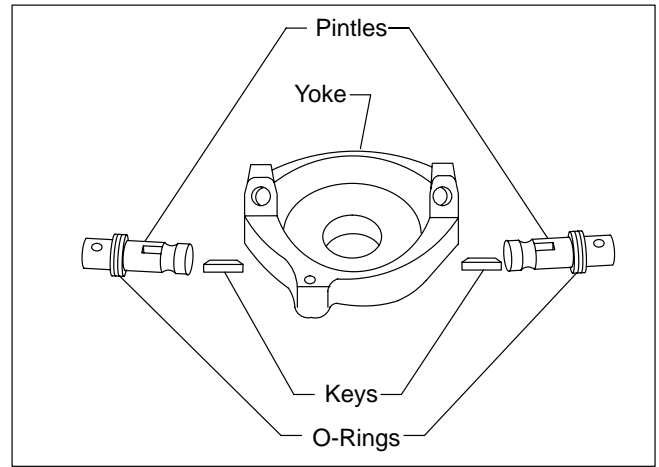

Step 23.

23. Here you see the yoke and pintles (with keys) in assembly sequence.

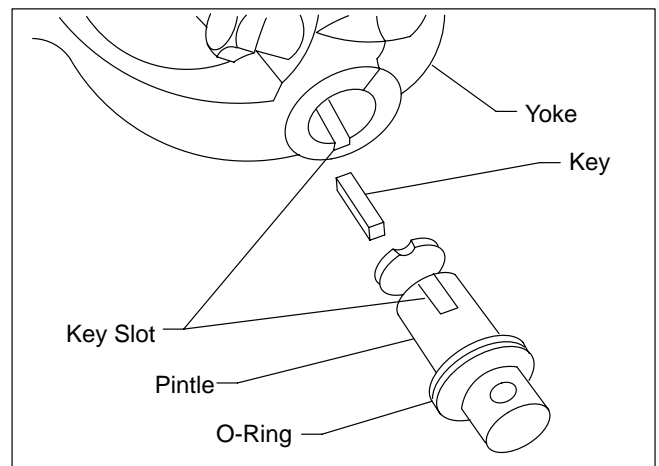

Step 24.

24. The figure shows one side of the yoke emphasizing the keyway, key, and pintle, which must be assembled with the key to lock the pintle to the yoke so that the yoke can be positioned from outside the transmission.

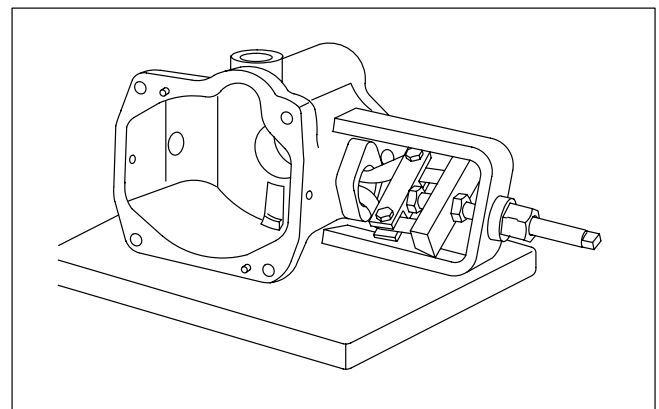

Step 25.

25. Once you have removed the yoke and pintles, you can pull the pintle bearings if necessary. Use the proper bearing puller as shown here.

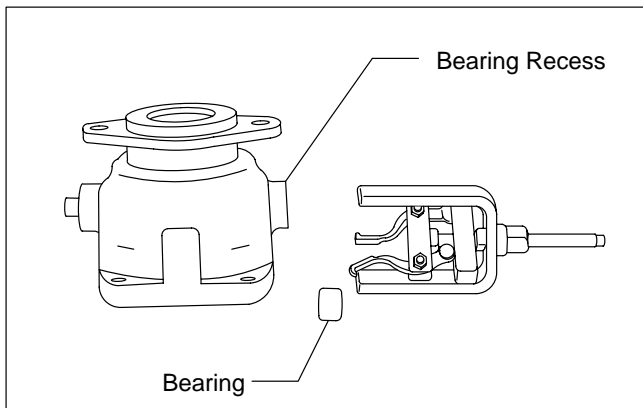

Step 26.

26. In this view, the pintle bearing has been removed.

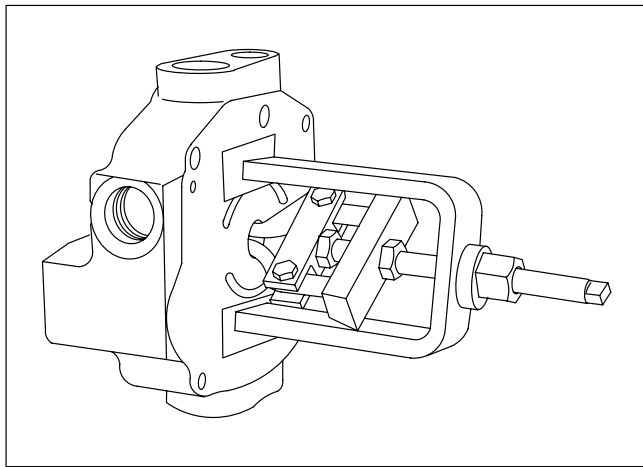

Step 27.

27. Again, use a bearing puller to pull the bearings in the valve plates. Be sure to protect the valve plate surface against scratches or nicks during the operation. Note that here we have used two pieces of copper or brass shim stock for this purpose.

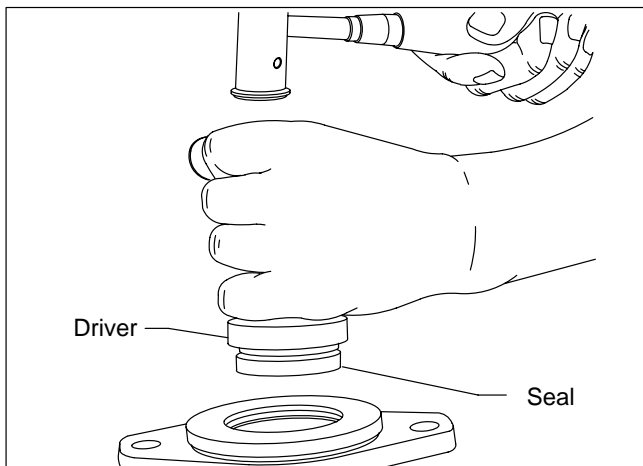

Step 28a.

28a. If the shaft seal is to be replaced, use a shaft seal driver of the proper dimension or an arbor press, if available.

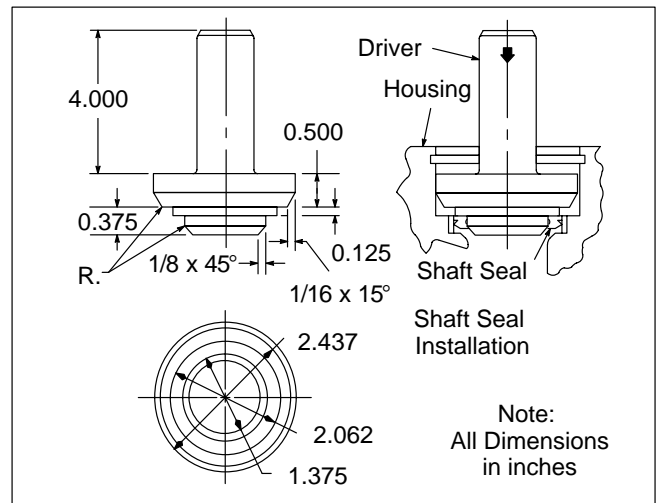

Step 28b.

28b. Position the shaft seal on the driver; then place the seal in position and drive it into the pump or motor housing as shown in (a). Shaft seal driver dimensions are given in (b).

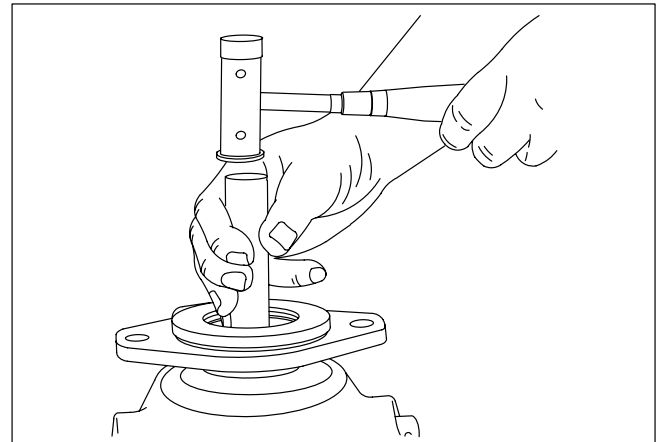

Step 29.

29. After the seal is in place, remove the driver.

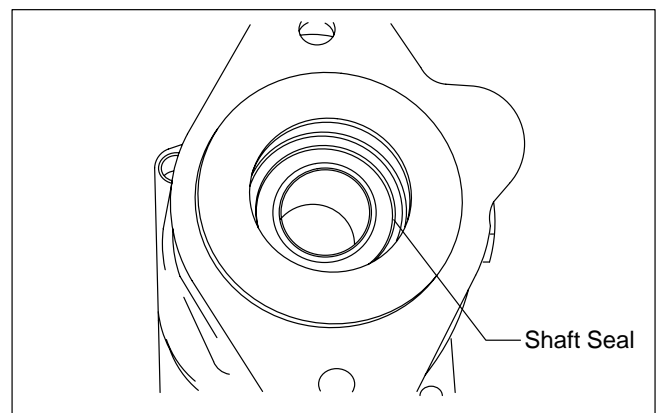

Step 30.

30. In this view, the shaft seal is properly seated and bottomed out against the shoulder of the recess.

The following sequence highlights the importance of applying proper torque to the screws in reassembly.

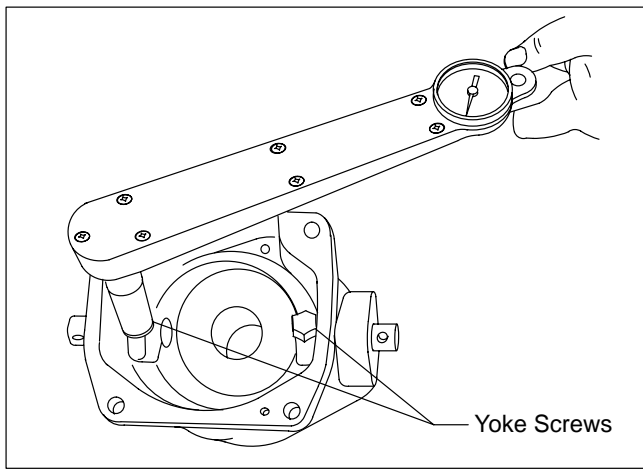

Step 31.

31. Torque the yoke screws at 55 to 60 ft-lbs.

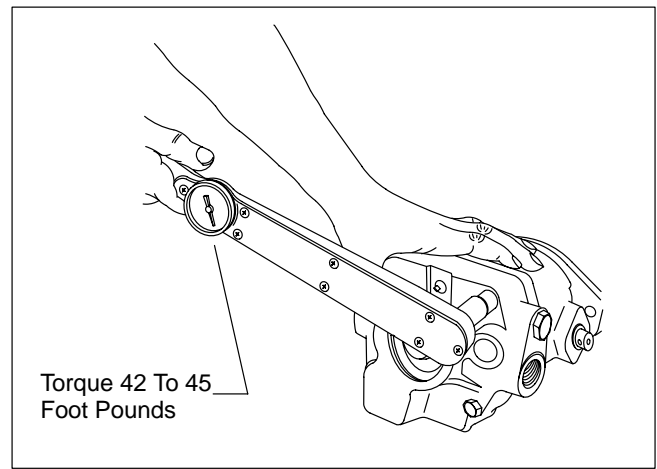

Step 32.

32. Torque the cover screws at 42 to 45 ft-lb.

Section V - Inspection and Repair

Clean all parts thoroughly with mineral spirits prior to inspection and after any stoning or machining operation. Inspection and repair procedures are as follows.

1. **Valve Plate** - Inspect the flat surface mates with the cylinder block for wear or scoring. Remove minor defects by lightly stoning the surface with a hard Arkansas stone that is flat within 0.001 inch. Be sure to stone lightly; the surface is hardened and excessive stoning will remove hardened surface. If wear or damage is extensive, replace the valve plate.

2. **Rotating group** - Inspect the bores and the valve plate mating surface of the cylinder block for wear and scoring. Remove minor defects on the running face by lightly stoning or lapping the surface. If the defects cannot be removed by these methods, replace cylinder block.

If one or more piston and shoe subassemblies need to be replaced, check that all piston and shoe assemblies in the unit ride properly on the swash plate (Figure 7). In a set of nine pistons, variations in thickness greater than 0.001 inch from one shoe to another, will result in excessive internal leakage and shoe wear. The replacement of all nine piston and shoe subassemblies in the pump and, as well as the cylinder block, is recommended for maximum service between overhauls.

If necessary, hand-lap the shoes with 500-A emery paper (Tuff-Bak Durite Silicon Carbide) backed-up by a lapping plate. Good results may be obtained by dipping the emery paper in kerosene and keeping it wet during polishing.

3. **Swash Plate** - Inspect the swash plate for wear and scoring. If the defects are minor, lightly stone the swash plate. If wear or damage is extensive, replace the swash plate.

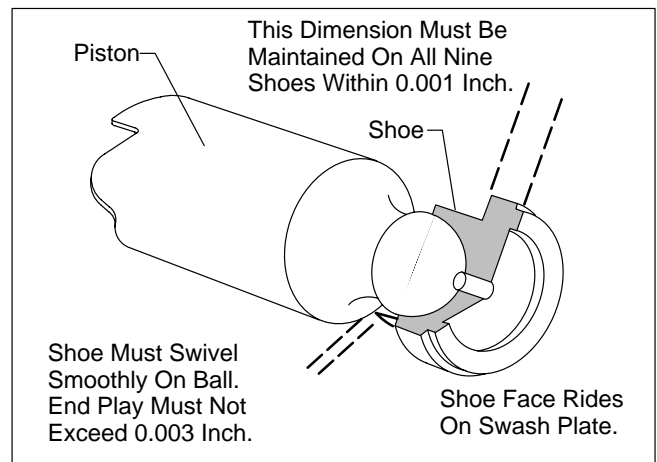

Figure 8.

4. **Bearings and Drive Shaft** - Inspect all bearings for roughness or excessive play; replace if necessary. Examine the sealing area of the shaft for scoring or wear. If the drive shaft is bent or worn excessively, replace it.

5. **Gerotor Assembly and End Plate** - Inspect the surface of all parts subject to wear. Light scoring may be removed from the faces of the end plate with crocus cloth (by placing the cloth on a flat surface), medium India stone or by lapping.

Section VI - Assembly

The procedures for assembling the pump are basically the reverse of the disassembly procedures shown in detail in Section IV. However, the following instructions describe certain additional procedures that should be adhered to:

Install new gaskets, seals, and O-Rings during assembly. To ease assembly of the gasket and seals, apply a thin film of Vaseline or clean hydraulic oil to the O-Rings. If a new rotating group is being used, squirt clean oil on it.

A. Piston Pump

1. **Yoke** - Install the yoke in the housing. With O-Rings in place, insert the pintles through the housing and into the yoke. Check that the yoke does not rub against the housing. Align the pintle holes with the holes in the yoke. Press in roll pins until they are 0.10 inch from the top of yoke.

2. **Drive Shaft and Bearing** - Install new shaft seal in the housing. Then install the drive shaft in the housing. Secure the drive shaft bearing with the retaining snap ring, making certain that the sharp edge on the snap ring faces out.

3. **Swash Plate** - Install the chamfered edge of the swash plate toward the shaft seal. Be sure that the swash plate is properly seated in the yoke and that it can be freely rotated with the fingers.

4. **Rotating Group Assembly** - If the spring and washers were removed from the cylinder block, reassemble them. When properly assembled with the three pins in place, the spring can be compressed about 1/8 inch.

Section VII - Start - Up After Repair

Take the following precautions when starting a vehicle after repair:

1. Fill transmission case with new, clean oil through case drain openings before connecting drain lines and before installing transmission in vehicle.

2. Connect all hydraulic lines to the proper transmission port lines and set hydraulic controls in neutral position.

3. Loosen or remove reservoir cap and add new, clean oil to reservoir.

4. Jog the starter several times with engine coil wire disconnected (for about one minute). Recheck reservoir oil level and if necessary add oil to maintain operating oil level.

5. Replace engine coil wire. Start the engine and run it to a speed of about 800 rpm (avoid high speed start-up). Recheck reservoir oil level again.

6. Move the controls to the forward position and run vehicle slowly on level ground for a few yards.

7. Then, after a short interval (about 10 seconds), place controls in reverse and move vehicle slowly backwards an equal distance.

8. After several short trips back and forth, the air should be expelled from your hydraulic system. Check the oil level; add oil if necessary.

After all the above steps are complete, you may operate the vehicle at regular speeds and loads. In cold weather, make sure the hydraulic components are warm to the touch before operating the vehicle.

Section VIII - General Maintenance

A. Lubrication

Internal lubrication is provided by the system oil flow.

B. Replacement Parts

Use only genuine parts manufactured or sold by Vickers Incorporated as replacement parts for these transmissions. Only Vickers knows the true quality level required of each part.

C. Adjustments

No periodic adjustments are required other than maintaining proper shaft alignment with the driving medium.

D. Adding Fluid to the System

When adding hydraulic fluid to the system, pour it through a 10-micron filter. If such a filter is not available, use a funnel with a fine wire screen (200 mesh or better).

E. Oil Filter

The oil filter controls the cleanliness of the oil. Experience with various kinds of duty and operating conditions will help you to determine how often to schedule a filter cartridge change. Check the condition of the oil periodically until you can establish a replacement pattern. In the meantime, change the cartridge after the first 50 hours of vehicle operation.

Experience with various kinds of duty and operating conditions will help you to determine how often to schedule a cartridge change. Check the condition of the oil periodically until you can establish a replacement pattern. In the meantime, change the cartridge after the first 50 hours of vehicle operation and every 500 hours thereafter.



CAUTION

It is important that oil be clean and free of all substances that could cause improper operation and excessive wear of any unit in the system.

F. Troubleshooting

The cause of improper functioning in a hydraulic system is best diagnosed with the use of proper and adequate testing equipment and a thorough understanding of the complete hydraulic system.



CAUTION

A hydraulic transmission unit that exhibits an excessive increase in heat or noise is a potential failure. When either of these conditions are noticed, immediately shut down the machine, locate the trouble, and correct it.

Detailed troubleshooting information is given in the following charts.

Section IX - Trouble, Cause, and Remedy Information

A. General

Transmissions are closed or open loop circuits; the same oil continuously circulates between the pump and the motor except for normal lubrication and cooling leakage which is made up by the supercharge (auxiliary) pump. The supercharge pump maintains a positive pressure at the system pump inlet.

If it is properly maintained, such a hydraulic system will give productive, trouble-free operation. However, heat, dirt, free-air, and cavitation can cause a malfunction in the system. The information below describes some of the symptoms of an improperly functioning system; the causes of such problems; methods of correcting them; and, consequently, ways of preventing expensive breakdowns.

B. Transmission Making Excessive Noise

Air in the system sometimes presents a "milky" appearance in your reservoir oil. A leak at the intake (suction) side of the pump will cause aeration in the fluid. When this condition exists, there is a mixture of free air with the oil. Since air is compressible, as it is pressurized and released within the high-pressure pump, an explosion of the tiny air bubbles occurs. This phenomenon may be translated into an audible sound above the normal hydraulic sound level. Air which is audible in the fluid system sounds as if marbles were going through the pump. Consequently, reduced lubrication and an erratic action in your hydraulic system results.

In the event of aeration in your hydrostatic pump, check the operation of the supercharge pump.

Cavitation is caused by a low-pressure condition at the inlet port of the piston pump. Vapor pockets are formed separating the oil molecules, resulting in a noisy and erratic operation of the hydraulic transmission. Serious erosion of the pumping unit parts occurs in a relatively short operational period.

A worn or failed replenishing pump is the primary cause of cavitation in a closed-loop hydrostatic transmission circuit.

Cavitation can also be caused by using **too heavy an oil** in the hydraulic system. After overhaul or when refilling with fluid, be certain to use recommended oil types.

During cold weather, the oil will thicken after standing idle overnight or for a considerable length of time. You may experience cavitation at initial start-up. This will disappear as the oil begins to warm up and thin out a little. (Be sure to follow the cold weather start-up procedures given in the oil recommendation data sheet).

C. Hydraulic Transmission Overheating

Overheating of the hydraulic system can cause system failure. When hydraulic oil becomes excessively hot, the fluid will oxidize. If oxidation occurs, the oil will not lubricate as well and the transmission will wear out faster.

As an example, the rate of oxidation will double for every 10 degrees of temperature rise over 160° F. At high temperatures, O-Rings, seals, and gaskets will deteriorate

Internal leakage is one of the reasons for excessive heat. If a pumping unit becomes worn, slippage occurs; that is, fluid will move through the leakage passages and create a rapid heat build up. This condition can be recognized by a slowing-down of the vehicle. **Field repair under these circumstances is not feasible.** Return the vehicle to the maintenance shop for exchange of transmission.

Another reason for excessive heat may be a plugged or **failed heat exchanger system.** This can be readily determined and a "field fix" is possible.

In summary, if the vehicle loses speed, especially after it has been operating for a while, check the temperature of the hydraulic system fluid. This can be done by immersing a standard thermometer (of sufficient range) in the reservoir. Compare the resultant temperature reading with your maximum operating temperature recommendations.

D. System Not Developing Pressure

There are two reasons for loss of pressure in hydraulic system: (1) **either one of the two relief replenishing valves has "failed open",** or (2) **you are losing the complete volume of fluid by internal leakage** (slippage) or external loss.

If the relief replenishing valve fails, the vehicle will generally move in one direction but not in the other (forward or backward). It is unlikely that both relief replenishing valves will fail simultaneously. Such failure may be checked by swapping relief replenishing valves from one side to the other.

If your vehicle slows down or will not move in either direction, the fluid supply may be going back to the reservoir by internal slippage, or a ruptured line or joint may be causing external loss of fluid

Of course, you should check for linkage or shaft disengagement.

E. External Leakage

Ruptured lines, loose joints, or worn gaskets and seals can cause leakage problems.

The line and joint leakage is obvious and simple to correct. However, seal or gasket leakage requires disassembly of part or all of the hydrostatic transmission. The possibilities are shaft seal leakage or leakage between the valve block and pump or motor externally. If an O-Ring within the unit is cut, worn, or hardened, internal leakage may occur as evidenced by a slowing-down action of the vehicle when in motion.

When replacing seals or gaskets, follow suggested disassembly procedures and use O-Ring seals of proper durometer, and recommended gaskets.

F. Miscellaneous

In troubleshooting a hydraulic system, do not overlook the possibility of mechanical failure of parts related to the hydrostatic transmission.

Check for sheared shaft keys, disconnected or mis-adjusted control linkage and disconnected or broken drive mechanisms.

If an overspeeding condition occurs, check your engine governor for malfunction.

The hydrostatic transmission is designed for long, trouble-free life if recommended maintenance procedures are followed. When trouble occurs, first check the most obvious possibilities. For successful operation and maintenance, make it a point to **know your hydrostatic transmission well.**

G. Trouble, Cause, and Remedy Chart

TROUBLE	PROBABLE CAUSE	REMEDY
Excessive noise in hydrostatic transmission	Air in system	Check for air leads on suction line. "Bleed" hydraulic lines at highest point downstream of replenishing pump and while system is under pressure.
	Vacuum condition	Check inlet (suction) lines and fittings for air leaks. Check replenishing pump function.
	Oil too thick	Be certain correct type of oil is used for refilling or adding to the system.
	Cold weather	Run hydraulic system until unit is warm to the touch and noise disappears.
Hydraulic transmission overheating	Internal Leakage	If established that excessive internal leakage is evident, return vehicle to maintenance shop for evaluation and repair.
	Heat exchanger not functioning	Locate trouble, repair and replace.
	Fluid level low	Add oil to operating level.
System not developing pressure	Relief replenishing valve open	Replace one or both. Do not attempt to repair cartridges, they are factory assembled and preset.
	Loss of fluid internally (slippage)	Return vehicle to maintenance shop for repair of hydraulic system.
Loss of fluid	Ruptured hydraulic lines Loose fittings	Check all external connections, tubing, and hoses. Tighten connections, replace ruptured tube or hose.
	Leaking gaskets or seals in hydrostatic transmission	Observe mating sections of hydrostatic transmission for leaks. Replace seals or gaskets if possible.
Miscellaneous	Sheared shaft key	Locate and repair.
	Misadjusted or broken control linkage	
	Disconnected or broken drive mechanisms	